

OM94001

Hi-Rail Vehicle Code

Issue number	Prepared (P) Reviewed (R) Amended (A)	Approved by	Approval date
1	W Powell (P) M McKeon (R)		10 May 2006
2	Albert Bossward (A)	Andrew Hunt	23 February 2016
3	Albert Bossward (A)	Andrew Hunt	18 March 2016
4	Network Mechanical TC (R)	Andrew Hunt	26 August 2016
5	Andrew Hunt (P) John Gardiner (R)	Alex Raue	8/7/24

Copyright ©

All information contained within this document is the intellectual property of KiwiRail Limited and shall not be copied (by any means) or used by any person or commercial entity without the specific written approval of the National Engineering and Asset Management Leader, KiwiRail Limited.



Contents

1. Introduction	6
1.1 Purpose	6
1.2 Status	6
1.3 Change requests	6
1.4 Change history	6
1.4.1 Updates to issue 2	6
1.4.2 Updates to issue 3	7
1.4.3 Updates to issue 4	7
1.4.4 Updates to issue 5	8
1.5 Scope	8
1.6 How to use this document	8
1.7 Responsibilities	9
2. Definitions	10
3. Policy	12
3.1 Compliance with this Code	12
3.2 When you must talk to KiwiRail	14
3.3 New projects	15
3.4 Scratchbuilt, modified or imported vehicle	15
3.5 Buy or hire vehicle already approved for NZ	15
3.6 Change of ownership	16
3.7 Certification and inspections	16
3.7.1 Approval of HRVs for use in tunnels	16
3.7.2 Approval of HRVs for use in CRL tunnel	17
3.8 Vehicle identify numbers	17
3.9 Speeds	17
3.10 Trailers and trolleys	17
3.11 Risk management	17
3.12 Motor vehicle design and construction	17
3.13 Fault and repair booking	17
3.14 Documentation	18
3.15 Equipment	18
3.16 Statutory requirements	18
3.17 Other requirements	18
3.18 Driver licensing	19
3.19 Training and competency	19
3.20 Incidents	19
4. Approvals	20

4.1	Type approval	20
4.2	New, modified or imported vehicle	20
4.3	Buy (change in ownership) or hire vehicle already approved for NZ	21
5.	Periodic inspection process	21
6.	Common design requirements	22
6.1	Profile & Height	22
6.2	HRV drive systems	23
6.3	Attachment to chassis and structural modifications	23
6.4	Wheel back-to-back dimensions	24
6.5	Wheel profiles	24
6.6	Standard wheels	24
6.7	Wheel nuts	24
6.8	Maximum axle load	24
6.9	Side-to-side wheel load balance	25
6.10	Twist negotiation	25
6.11	Loads on rubber tyres	25
6.12	Insulation	26
6.13	Earth path	26
6.14	Stability	26
6.15	Warning lights	27
6.16	Hazard lights	27
6.17	Reversing beeper	27
6.18	Horn	28
6.19	Train Control radio	28
6.20	Maximum speed	28
6.21	Speedometer	29
6.22	Brake performance on rail	29
6.23	Parking brake	31
6.23.1	Existing HRVs	31
6.23.2	CRL Grade Suitable, new HRVs, and changed requirement for all HRVs	31
6.23.3	General park brake requirements	32
6.24	Brakes – all types	33
6.25	HRV safety systems	33
6.26	Pressurised systems	33
6.27	Mechanical systems	34
6.28	Cranes and elevating work platforms	34
6.29	Machine controls	34
6.30	Interlocks	35
6.31	Fire safety	35
6.31.1	Fire fighting	36



6.31.2	Thermal protection	37
6.31.3	Electrical protection	38
6.31.4	Fluid containment	39
6.32	Guidelines on applying fire safety measures	40
6.33	Exhaust systems	41
6.34	Footsteps and handgrabs	42
6.35	Cab	42
6.36	Operating position	42
6.37	Electrical systems	42
6.38	Marking and documentation	42
6.39	Hi-rail light trailers	43
6.40	Trolleys used with HRVs	44
6.41	Operator protective structures (OPS)	44
7.	Specific design requirements	45
7.1	Cranes and elevating work platforms (EWP)	45
7.2	Pantographs	46
7.3	Self-laying tracks	46
7.4	Excavators	46
7.5	Imported HRVs	47
7.5.1	Policy	47
7.6	Crawler carriers	48
7.7	Pivot-steer vehicles	48
7.8	Vehicle Safety Indicator Lights	48
8.	Appendix A. Test procedures	49
8.1	A1. Measuring rail wheel geometry	49
8.2	A2. Measuring rail wheel loads	51
8.3	A3. Measuring twist response	52
9.	Appendix B. Charts	53
10.	Appendix C. Drawings	63
11.	Appendix D. Checksheets	69
12.	Appendix E Type approval certification	70
12.1	Overview	70
12.2	Certification and certifier details	70
12.3	Vehicle description	70
12.4	Compliance statements	71
12.5	Limitations and conditions	71
12.6	Vehicle Documentation	71
13.	Appendix F. Risk management	72
13.1	Overview	72

13.2	Content	72
14.	Appendix G. Manuals	73
14.1	Overview	73
14.2	Content	73
15.	Appendix H. Training and competency syllabus	74
15.1	Overview	74
15.2	Content	75
16.	Appendix I. KiwiRail-supplied items	76

1. Introduction

1.1 Purpose

This Code:

- Updates, and renames, 'OM94001 Hi-Rail Vehicles (HRVs) for use on the Controlled Network' Issue 1 dated 10 May 2006, and updates Issue 2 dated 7 October 2015, and Issue 3 dated 18 March 2016, and Issue 4 dated 26 August 2016.
- Defines the policies, processes and design standards for approving and maintaining HRVs intended for use on the Network.
- Provides guidance for people or organisations planning to purchase, import, manufacture or modify such vehicles
- Specifies an Entry Approval Checksheet and requirements for a Type Approval Certification for new, modified or imported vehicles.
- Specifies a Loco 160A HRV Inspection Checksheet examination and issuing a Loco 155B Rail Certificate of Fitness.

1.2 Status

This Code is a Mechanical Code Supporting Document. It is to be used in conjunction with the following documents:

- M2000 Mechanical Code

1.3 Change requests

Please send any requested changes to this document to the document controller:
document.controller@kiwirail.co.nz.

1.4 Change history

1.4.1 Updates to issue 2

Improvements are focused on the robustness of fundamental processes covering equipment certification, safety assessments, instructions, training and maintenance. Experience from NZ and overseas has shown fundamental omissions or errors, often as a result of 'organisational gaps' between industry participants, have been the main contributors to many significant accidents. Typically, these have included crew unfamiliar with their equipment as they were not adequately trained, or not trained at all, and equipment that was not adequately rated, or not adequately assessed or tested.

In NZ, HRVs are a diverse range of complex and often unique or small run equipment, certified by different people and often used over long distances and under construction site conditions. Operator training and competency must allow for the diversity of equipment, contracting companies and day to day crew.

A holistic safety management approach is taken to improve engineering and operational outcomes across the vehicle life cycle. Processes will be clearer and easier to follow while being more comprehensive in the evidence needed to show compliance. A flexible performance-based approach is preserved over detailed prescription. Key new requirements are:

- Improving engineering certification with regard to consistency, scope and thoroughness including handover to owner and operator with support around safety, manuals, training and maintenance.
- Including relevant handover acceptance by the vehicle operator including safety mitigations, residual hazards, training and competency checks.

Requiring evidence of manuals, maintenance and training for ongoing access to the Network.



Policy documents issued separately after May 2006 are included in this updated Code:

- Requirement for Certifying Engineer to be of Chartered status and independent from vehicle owner and operator (see section 2 [Definitions](#)).
- Operator protective structure (OPS) (see 6.41 [Operator protective structures \(OPS\)](#))
- Elevated work platforms (EWPs) (see 7.1 [Cranes and elevating work platforms \(EWP\)](#))
- Excavators (see 7.4 [Excavators](#))
- Imported HRVs (see 7.5 [Imported HRVs](#))
- Crawler carriers (see 7.6 [Crawler carriers](#))
- Pivot-steer HRVs (see 7.7 [Pivot-steer vehicles](#)).
- Training (see [Appendix H. Training and competency syllabus](#)).

1.4.2 Updates to issue 3

Material added at 6.22 (2) to cover brake performance in the event of failure.

1.4.3 Updates to issue 4

Improvements are focused on Tunnel Suitable requirements and fire safety, deadline for minimum standards for vehicle manuals, and added emphasis on vehicle recertification after modification or major repair. Key new or modified requirements are:

- 3.7 Requirement for contractors to apply for 160A inspection from 1 October 2016
- 3.7.1 Approval of HRVs for use in tunnels
- 3.8 & elsewhere the term KiwiRail “serial number” is replaced with “identity number”.
- 3.13 Requirement for fault and repair book
- 3.14 Minimum vehicle manual requirements from 1 Dec 2016.
- 6.1 Vehicle height in electrified areas
- 6.22 Brake performance. Note especially item 5 advising of changed requirements for existing vehicles that brake on less than four wheels.
- 6.31 Fire safety measures and requirements for AFFSS.
- 6.32 Guidelines on applying fire safety measures.
- 7.1 Cranes and EWPs. Point 2 deleted to recognise normal off-rail practice.
- Appendix D Checksheets have been removed from the manual and now exist as standalone documents with the following changes:
 - Check sheets updated to cover Tunnel Suitable requirements.
 - Existing Type Approval renamed to Entry Approval to avoid confusion with type approval by a Certifying Engineer.
 - Pre-journey check sheet added including routine Tunnel Suitable checks.
 - Contractor application for 160A inspection added.
 - 160A inspection revised and includes Contractor application, evidence of fault and repair booking system and records, evidence of training and risk assessment endorsement at ownership change.
- Appendix G and elsewhere emphasising recertification after modification.

1.4.4 Updates to issue 5

Changes provide for the particular requirements of the City Rail Link (CRL) tunnel and its increased track gradient of 1 in 30. Key new or modified requirements are:

- Definitions
- 3.7.1 Approval of HRVs for use in tunnels
- 3.7.2 Approval of HRVs for use in CRL tunnel
- 6.23 Parking brake.

Minor amendments to also consolidate changes made in Issue 4 that are fully phased in (phase-in period was 2016 / 2017)

Incorporated Significant Information Notices (SINs) published since Issue 4. Specifically:

- SIN-M20-001 *Hi-Rail Safety Indicator Lights* (issued 18/02/2020) – incorporated as new Section 7.8
- SIN-M20-002 *HRV E-Stop Operation – Code Change* (issued 18/02/2020) – incorporated in Section 6.31.1

1.5 Scope

This Code applies to the design, build, test, type approval and periodic certification of all HRVs used on the Controlled Network or under KiwiRail's Safety Case from the effective date of the document.

"On-track plant" that can be jacked or traversed off track, but cannot operate off track, are not covered by this Code.

This Code is written for vehicles up to 12tonne tare weight and trailers up to 2tonne gross weight. Vehicles over these weights must also comply but may require further management and must be assessed on a case-by-case basis by KiwiRail.

Requirements for the attachment of Hi-Rail equipment to a vehicle chassis, and the possible effect on vehicle performance for compliance with road vehicle standards, are outside of the scope of this Code and must be separately certified.

1.6 How to use this document

Section 2 includes definitions of some common terms or acronyms used throughout the document.

Section 3 sets out KiwiRail's overall policies for engineering and operational compliance and whole of life support including risk assessment, manuals, maintenance, training and competency. Flow charts with commentary are used to illustrate the workflows and KiwiRail approval stages.

Sections 4 and 5 set out the type approval process and periodic inspection process.

Section 6 gives a comprehensive list of design requirements common to HRVs, while Section 7 provides specific requirements for vehicles such as elevated work platforms (EWPs), excavators and crawler carriers.

Wherever possible, KiwiRail will recommend best practice approval process guidance.

The Appendices include examples of test procedures, drawings to illustrate components, measurements etc, check sheets and checklists, type approval certification, risk management, manuals and training, as well as sourcing KiwiRail-supplied items.

Checklists can be supplied by contacting KiwiRail.

Tips and hints

Helpful recommendations and other useful information, including key points to note, is included throughout the Code in boxes like this.

1.7 Responsibilities

The rail corridor is different from an ordinary construction site, and activities on rail are also covered by the Railways Act 2005 (the Act). The Act requires all rail operators to hold a licence. A rail operator is a person who provides or operates a rail vehicle. A rail vehicle is any vehicle that runs on a railway line. A hi-rail vehicle is classed as a rail vehicle but only when it is on a railway line. To obtain a licence, a rail operator must have a 'safety case' approved by the NZ Transport Agency (NZTA). The safety case describes the rail operator's activities and how the operator will keep things safe. OM94001 (this code) is a part of KiwiRail's safety case.

Most contractors working for KiwiRail operate under KiwiRail's licence, so must comply with KiwiRail's safety case. KiwiRail is also the Access Provider under the Act. That is why KiwiRail has a particular interest to manage HRVs to ensure safety and ensure it complies with its licence.

However, a hi-rail vehicle owner or operator remains entirely responsible for providing, maintaining and operating the vehicle to the requirements of this Code, its certification conditions, maintenance and operating requirements.

Further information on safety cases and licensing requirements may be found on the NZTA website:

<http://www.nzta.govt.nz/commercial/rail/licensing.html#holders>

2. Definitions

Term	Definition
ACoP	Approved Code of Practice, eg, for cranes, EWPs etc.
AFFSS	Automatic Fixed Fire Suppression System . An installed fire suppression system that includes automatic activation in the event of a fire.
CBIP	Certification Board of Inspection Personnel. It provides a comprehensive competency based certification service to industry, including for Cranes, Welding, Pressure Equipment, Elevated Work Platforms and Lifts.
Certifying Engineer	Chartered Professional Engineer NZ (CPEng) acceptable to KiwiRail who is independent of vehicle owner and the vehicle supplier/builder/manufacturer, or, other person acceptable to KiwiRail (Ref: ipenz.org.nz).
CoF, WoF	Road Certificate of Fitness and Warrant of Fitness.
Crew	Staff directly controlling the HRV.
CRL Suitable	An interim status for Tunnel Suitable HRVs also rated as fit to operate in the City Rail Link tunnel's steep gradient. To be integrated into general requirements then phased out.
Direct drive	Rubber tyred road wheels, or approved self-laying tracks, directly onto rail – see RISSB definition.
Entry Approval Checksheet	Detailed check of vehicle parameters undertaken as part of a first inspection before granting network access. Inspections are undertaken by KiwiRail.
E-Stop	Emergency stop device
EWP	Elevated work platform.
Fail-safe	If a component fails the system or vehicle fails in a safe condition eg, brakes applied rather than brakes released.
Friction drive	Rubber-tyred road wheels driving onto a drum or hub which drives the rail wheels or driving directly onto the rail wheels (Friction drive onto the rail wheels is not encouraged).
Heavy HRV	A rail capable truck, with tare weight more than 5t, used to transport people, equipment or materials to a site, or to carry out on-rail tasks such as inspections, grease dispensing, weed spraying, drain cleaning, etc.
Heavy Vehicle Specialist Certifier	Engineer appointed by NZTA to certify specific aspects of the configuration and modification of commercial vehicles for use on NZ public roads.
Hi-Rail Light Trailer	A road trailer with rail capability, with gross weight less than 2t, used to transport equipment or materials to a site, or to carry out on-rail tasks such as grease dispensing, weed spraying, drain cleaning, etc. For rail-based trolleys that do not have road capability, refer to the "Trolley" definition.
HRV	A vehicle fitted with retractable rail wheels so that it can be driven along the track and can be driven onto or off the track at level crossings or other suitable places, and operated on or off track.
Light HRV	A rail capable truck, utility, car, bus or van, with tare weight less than 5t, used to transport people, equipment or materials to a site, or to carry out on-rail tasks such as inspections (LIV: Light Inspection Vehicle), grease dispensing, weed spraying, drain cleaning, etc.
Loco 155B	Rail Certificate of Fitness (sticker displayed in vehicle cab) issued by KiwiRail; referred to as Loco 155B RcoF sticker.
Loco 160A	HRV Inspection Checksheet. Applies to all HRVs initially, then at 6 monthly intervals as periodic inspection.

Term	Definition
Network	For the purpose of this Code, Network represents both NRSS/1 definitions: 1) Controlled Network: all track where occupancy and movement by rail vehicles is under the control of KiwiRail.2) National Rail System: the rail network comprising the Controlled Network and Operator Controlled Territory. It includes all track owned or managed by KiwiRail (including private sidings) and all retained track, unless specifically defined as unavailable for rail activity.
NRSS	National Rail System Standard. These are available from KiwiRail or can be downloaded from the KiwiRail website www.KiwiRail.co.nz (http://www.kiwirail.co.nz).
NZTA	New Zealand Transport Agency (previously Land Transport NZ).
OEM	Original equipment manufacturer of a vehicle or component recognised by KiwiRail.
Operator	For the purposes of this Code, Operator is the management and/or crew responsible for using the HRV. This is intended as the higher level responsibility. For reference, NRSS/1 defines the Operator as any person (directly) granted Access Rights by the Access Provider etc.
OPS	Operator Protective Structure
Specialist Hi-Rail Plant	Equipment such as excavators, crawler carriers, pivot-steer vehicles, cranes, EWPs, vegetation cutters, etc that have been made rail capable to allow access to a place of work not otherwise able to be reached by road.
TPA and TPBM	Track Protection Advanced, and, Track Protection Basic Machine. KiwiRail crew qualifications for On-rail use of HRVs.
Tunnel Suitable	HRVs rated as fit to operate in tunnels longer than 200 m
Trolley	An unpowered rail vehicle for use only on rail and towed by another vehicle. This Code covers use with powered HRVs. Refer to OM94002 for further requirements.
Type Approval Acceptance	KiwiRail correspondence accepting the Certifying Engineer's Type Approval Certificate and granting Network Access rights.
Type Approval Certificate	Design compliance certificate issued by the Certifying Engineer. This may cover other vehicles of the same design as specified by the Certifying Engineer.

Notes:

The terms Hi-Rail, Hy-rail, Road/Rail and Road-Rail have all been used to describe this type of vehicle. In this Code, HRV is used in the general sense when discussing all or any form of Hi-Rail equipment (Heavy, Light, Specialist and Trailer).

Refer to NRSS/1 for definitions not provided in this Code.

3. Policy

3.1 Compliance with this Code

This Code influences the entire life cycle of HRVs. Management of all stages is needed to ensure compliance with KiwiRail's Rail Licence. All stages are interlinked and specific to a particular vehicle or equipment type. Some stages such as training and competency assessment may not automatically transfer across to a new operator.

Note that some repairs and most modifications will require recertification. If in doubt whether or not recertification is required consult KiwiRail.

The workflows needed to achieve KiwiRail approval to operate on the network are shown by Figure 1 and Figure 2. Down the middle are steps that must be completed, on the left are source information (within this Code) or documents such as checksheets, and on the right are the results from completing each step.

Compliance is to be based on evidence of outcomes. KiwiRail may audit any stage at any time including supporting documentation. Evidence will be needed that operators have manuals and have undertaken maintenance and training.

The Code applies to KiwiRail-owned vehicles and externally owned vehicles. KiwiRail may Certify its own HRVs and undertake maintenance and inspections concurrently.

HRVs that cannot practically be made fully compliant to this Code may be accepted on the Network subject to operating restrictions, which may be significant. HRVs that in KiwiRail's opinion can reasonably be made compliant with the Code must be made compliant.

The following sections provide commentary on work flows and responsibilities shown in Figure 1 and Figure 2, and outline the evidence-based approvals required to allow operation on the Network. The figures refer to the relevant clauses across sections 3, 4, 5 and Appendices.

Appendices are mandatory where relevant.

Effective dates

New requirements for type approval introduced in this issue of the Code take effect from the document issue date. That means that if you have a current Type Approval Certificate for a vehicle, eg, an excavator, you do not need to meet the new requirements for excavators.

However, if you start the type approval process for a new excavator after the effective date of this issue, you will need to meet the new requirements.

Use of older HRVs in tunnels will require compliance with policy listed in section 3.7.1 *Approval of HRVs for use in tunnels*

Use of older HRVs in the City Rail Link (CRL) tunnel will require compliance with policy listed in 3.7.2 *Approval of HRVs for use in CRL tunnel* and 6.23.2 *CRL Grade Suitable, new HRVs, and changed requirement for all HRVs*.

Process for scratchbuilt, modified or imported vehicle



Figure 1: Process for scratchbuilt, modified or imported vehicle.

Process for vehicle already approved in New Zealand: changing ownership, changing operator, or hiring vehicle

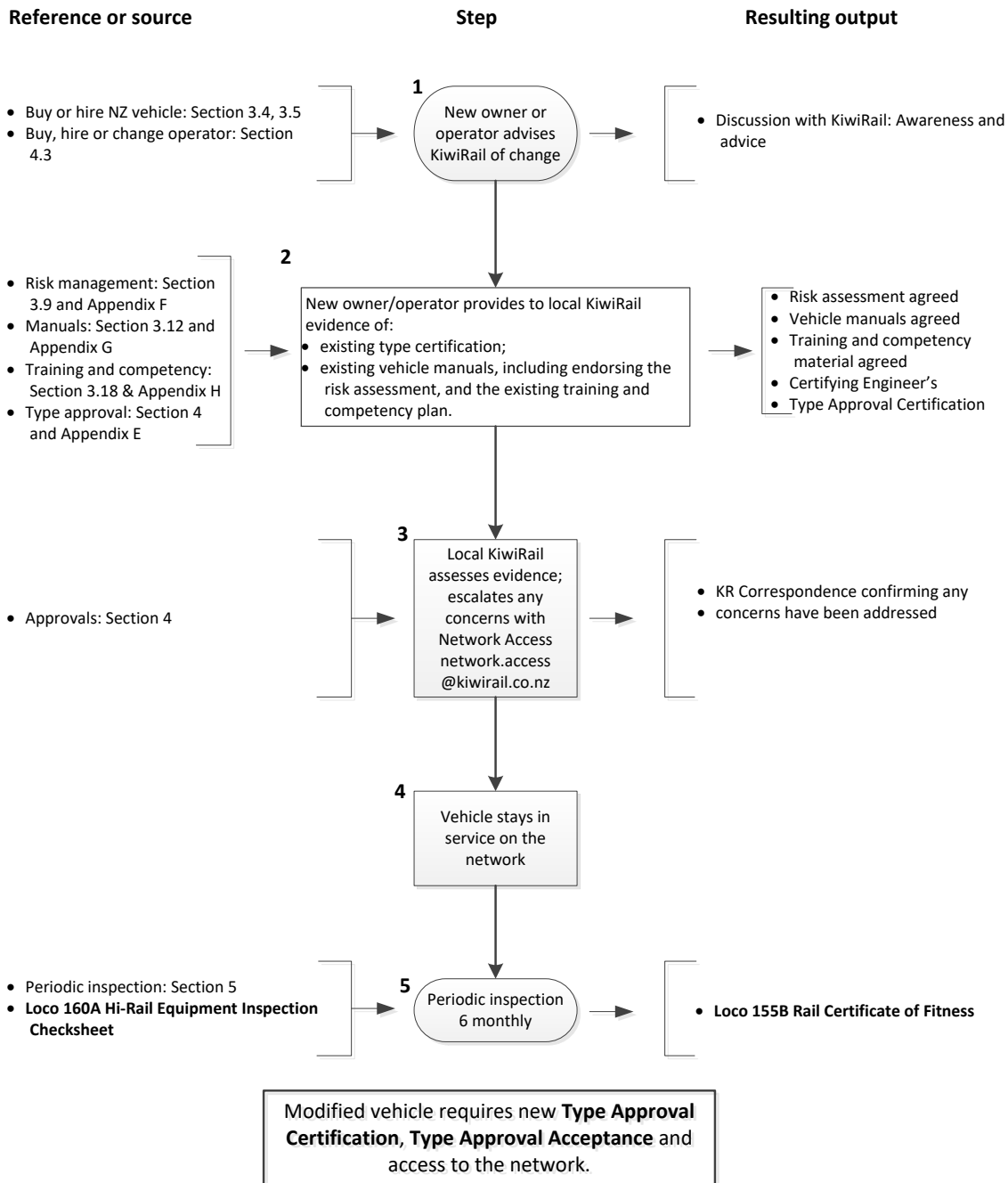

Figure 2: Process for vehicle already approved in New Zealand: changing ownership, changing operator, or hiring vehicle.

3.2 When you must talk to KiwiRail

There are occasions when you must advise KiwiRail of events or intentions. Other Policy sections provide more information on specific events. If in doubt contact KiwiRail for advice, For guidance, you must contact KiwiRail when:

1. Registering a new hi-rail
2. Modifying an HRV in any way that affects the hi-rail gear itself, weights on wheels, duty cycles, stability, braking or any other rail-related equipment is affected. KiwiRail will advise whether recertification is required.
3. A hi-rail has an equipment failure or needs a major repair.
4. Vehicle ownership changes.



3.3 New projects

KiwiRail encourages innovation to improve safety and productivity. To ensure new projects are well planned and well executed, KiwiRail needs to be aware of the project and make an early determination on any special requirements or approvals:

- Project initiator should advise KiwiRail of the intention to undertake the purchase, importation, modification or creation of a HRV and discuss the extent of work that might be needed.
- Project initiator should discuss with a Certifying Engineer the scope of engineering requirements to establish the project scope and resourcing that might be needed.
- KiwiRail and the Certifying Engineer should discuss the scope and approvals that might be needed, particularly if novel or special requirements are involved. Note that KiwiRail may need to apply to NZTA for a Safety Case variation for some new vehicles and extra time will need to be allowed for this.
- An initial risk assessment will be needed for any significant aspects untried in NZ.

Starting out

KiwiRail strongly recommends manufacturer, owner and operator of HRVs that will require type approval discuss requirements with KiwiRail before they commit to a new project.

3.4 Scratchbuilt, modified or imported vehicle

The vehicle owner is ultimately responsible for presenting the new, modified or imported vehicle with all supporting documentation to KiwiRail before type approval will be granted. The owner must therefore engage the necessary resources to support the engineering and documentation work.

It is essential the engineering and operational outcomes have been co-ordinated and integrated to ensure the final vehicle is fully understood, including how it should be operated, covering both the generic and unique hazards and safety issues related to that particular vehicle. To demonstrate compliance with this code, the following evidence will be needed:

- Risk assessment of mitigated hazards across design, maintenance and operations.
- Certification of vehicle to KiwiRail and all relevant regulatory requirements.
- Operating and maintenance instructions.
- Training and competency assessments.

Imported vehicles need to satisfy the above four requirements but the scope of work needed to achieve this will vary greatly depending on the vehicle condition, acceptable support documentation already available and any modifications needed.

Engineering emphasis for the equipment is to be correctly rated, have systems of high integrity, thorough assessment for compliance and preparation of adequate documentation for operational use. The Certifying Engineer is responsible for defining operational capabilities and safe limits for the vehicle, engineering certification (design/build/test) and inspection, servicing and scheduled maintenance requirements.

Operational emphasis is for the equipment to be operated safely and all ongoing risks to be adequately mitigated. The owner and/or operator is responsible for ongoing training and competency assessment of staff, providing support documentation and ensuring condition monitoring, maintenance and corrective action is undertaken.

3.5 Buy or hire vehicle already approved for NZ

Responsibility for safe operations rests with the operator of the vehicle, whether they are the owner or hirer of the vehicle. An operator that purchases or hires a vehicle type that has previously been approved for use on the network, but is new to them, must demonstrate they have the manuals, endorse the risk assessment and completion of training and competency for that vehicle type.



3.6 Change of ownership

KiwiRail should be advised of any change in ownership of vehicles that will be used on the Network. This advice should come from the purchaser. The requirements of section 3.5 [Buy or hire vehicle already approved for NZ](#) apply.

3.7 Certification and inspections

All HRVs and hi-rail light trailers must be certified for both rail and, where applicable, road operation. When they should be road worthy (as part of the overall compliance regime) they must have a current CoF/WoF to be accepted on the Network.

For rail use, six-monthly inspections using Loco 160A Hi-Rail Equipment Inspection Checksheet must be carried out followed by the granting of a Loco 155B. These may be achieved up to two weeks before becoming due while maintaining the originally scheduled coverage period.

Hi-Rail equipment must display:

- A current Loco 155B. On a self-propelled vehicle, this should be located on the inside of the driver's side B pillar, or alternatively above the driver's door. On a Hi-Rail Light Trailer it should be located in a protected location on the drawbar (such as the inner face of an A-frame), at the coupling end.
- A current road vehicle registration, if applicable.
- A current road vehicle WoF or CoF, if applicable.

KiwiRail will use the 6 monthly periodic inspection as an audit on maintenance (and operation) of the vehicle. Vehicles presented should already be compliant to the Code and fit for operation on the Network.

Non-KiwiRail operators presenting vehicles for inspection must present:

- A completed Loco 711: Application for Hi-Rail Periodic Inspection form.
- A completed Loco 160A Hi-Rail Periodic Inspection Checksheet.
- Evidence that necessary maintenance has been completed.

Where some small operators do not have the equipment to complete all inspections, KiwiRail will check those items by prior agreement.

3.7.1 Approval of HRVs for use in tunnels

Only HRVs rated as Tunnel Suitable are permitted to operate in tunnels longer than 200 m, unless allowed under a specific site safety plan that provides for fire safety and air quality. Tunnel suitable HRVs will be issued with a Tunnel Suitable endorsement sticker, to be displayed alongside the 155B.

HRVs which are not Tunnel Suitable will be issued with a Tunnel Restricted sticker to be displayed alongside the 155B.

To qualify as Tunnel Suitable, HRVs must meet the relevant requirements of sections:

- 6.26 Pressurised systems
- 6.31 Fire safety and
- 6.33 Exhaust systems.

See also section 6.32 *Guidelines on applying fire safety measures*

To qualify as CRL Suitable, HRVs must meet the Tunnel Suitable requirements and the CRL Suitable requirements of section 6.23 *Parking brake*.

Tunnel Suitable vehicles must be checked pre-journey before tunnel use using the Loco 712: Vehicle Inspection Checksheet. Contractors may use their own check sheets but must include the items from Section 2 for Tunnel Suitable vehicles.

3.7.2 Approval of HRVs for use in CRL tunnel

Only Tunnel Suitable HRVs that are also rated as confirmed as meeting park brake requirements for a 1 in 30 track gradient (see section 6.23.2) may be used in the CRL tunnel. This requirement is being phased in as follows:

- Tunnel Suitable HRVs that comply with the 1 in 30 track gradient requirement will be issued with a CRL Grade Suitable endorsement sticker, to be displayed alongside the Tunnel Suitable sticker until 31 January 2025.
- All HRVs that do not comply with the 1 in 30 track gradient requirement will be issued with a Grade Restricted sticker (1 in 33, or 1 in 90 for legacy excavators with hydraulic retardation per 6.22 §5). These stickers are to permanently remain displayed.
- By 1 February 2025, all HRVs – including Tunnel Restricted HRVs – will meet the 1 in 30 track gradient requirement or have a Grade Restricted sticker displayed.
- CRL Suitable stickers will be removed no later than the next 160A inspection after 1 February 2025.

Where compliance to the 1 in 30 track gradient requirement is untested for existing vehicles (certified to issue 4 of this Code or earlier), a Grade Restricted sticker (1 in 33) shall be fitted until compliance is confirmed by test.

3.8 Vehicle identify numbers

KiwiRail will assign a identity number to each hi-rail vehicle, as Loco 155Bs are issued to allow traceability of each vehicle through changes in certifications, ownership or lease.

3.9 Speeds

Light or heavy HRVs and hi-rail trailers that are fully compliant with the standards defined in this Code, when certified, are permitted to operate (with appropriate authorisation) on the Network at speeds not exceeding 50 km/h.

If specialist HRVs cannot comply with the requirements of this Code, they may be accepted for operation on the Network subject to approval by KiwiRail and significant operational restrictions, including a maximum speed on rail of 25 km/h.

3.10 Trailers and trolleys

Hi-rail light trailers for use with HRVs must comply with the requirements of this Code.

Trolleys for use with HRVs must comply with the requirements of this Code and OM94002.

3.11 Risk management

Risks must be managed in accordance with the requirements of NRSS/4 – Risk Management. Type approval or Loco 155B RCoF sticker will not be granted until KiwiRail has approved the risk assessment procedure.

When a new project involves any significant aspects untried in NZ, an initial risk assessment will be needed. Requirements will be decided when the owner first advises KiwiRail of the project.

Risk assessment will need to be reconsidered after vehicle modifications. KiwiRail can advise requirements as per 3.2 [New projects](#). See [Appendix F. Risk management](#) for risk assessment.

3.12 Motor vehicle design and construction

All motor vehicle design and construction must be to standards approved by the vehicle manufacturer and to applicable statutory requirements for vehicles for use on NZ public roads.

3.13 Fault and repair booking

All self-propelled HRVs must have a recording method kept in the operating cab or control station which allows operating crew to view and record faults, problems and repairs needed, and, allow maintenance staff to record corrective actions.

Note that a major repair may constitute a modification needing recertification. Discuss major repairs with KiwiRail if other than like for like replacement. Vehicles that have had major repairs should not be used in tunnels until satisfied that the vehicle is operating correctly.

An owner or operator that has an alternative 'in-house' recording process that is acceptable to KiwiRail may use that system instead.

3.14 Documentation

Comprehensive manuals covering operating instructions, servicing, maintenance, training and competency must be provided as set out in Appendix G.

Manuals must be finalised before training and competency checks can be completed.

The operator's manual and evidence of fault and repair booking, maintenance and training outcomes will be needed before KiwiRail will grant or renew a Loco 155B RCoF sticker.

Manuals on the HRV must be available by hard copy or softcopy readable on portable devices.

HRVs must carry a manual that includes as a minimum the following items from Appendix G:

- Safety page including emergency procedures (runaway etc.)
- Inspection and maintenance schedules
- Copies of original vehicle certificates
- An illustrated checklist showing all safety and operational signage and labels and their location.
- Training and competency syllabus (Appendix H)

Refer to Appendix G for particular requirements.

3.15 Equipment

All HRVs (except hi-rail light trailers) must carry the following equipment:

- the approved operating manual for the hi-rail equipment.
- a full set of safety equipment including:
 - red and green signalling flags
 - detonators
 - fire extinguishers (see section 6.31 Fire safety measures)
 - first aid kit
 - torch.

Note: Location specific equipment such as crew respiratory protective equipment (RPE) may need to be carried on some vehicles, such as those used on tunnels.

3.16 Statutory requirements

This Code focuses on HRVs and assumes statutory requirements have been satisfied. Statutory requirements are not specifically listed in this Code. However, Appendix E lists some typical compliance evidence needed for Type Approval Certification.

The vehicle owner and operator are responsible for compliance with these requirements.

3.17 Other requirements

This Code generally lists only requirements unique to HRVs. Specific requirements for particular work types or locations, such as tunnels or electrified areas, will also apply to HRVs as well as other equipment.

3.18 Driver licensing

Drivers of HRVs must hold:

- A current road driver's licence for the vehicle class concerned
- KiwiRail TPA or TPBM qualifications depending on work to be undertaken.

3.19 Training and competency

Training and competency assessment outcomes must be based on an understanding of the equipment as defined by the Certifying Engineer (see [Appendix E Type approval certification](#)), agreed risk assessment (see [Appendix F. Risk management](#)) and manuals developed to support the equipment (see [Appendix G. Manuals](#)).

The HRV owner is responsible for preparing documentation, training and competency assessment. The training syllabus/requirements are to be set out as a check-sheet and included as an appendix to the operator's manual.

Competency assessment must determine if crew are familiar and experienced enough to be a sole operator or person in charge, or, define supervision and review(s) to achieve this.

Documentation and any assessments are to be reviewed after any vehicle modifications.

Operators must always have up-to-date training and competency assessments for the equipment type they are operating, counter signed by operating management and sample crew, whether vehicle is owned, leased or hired.

Sample training material signed by trainee and trainer for each specific type of HRV will be needed as evidence before KiwiRail will grant a Loco 155B RCoF sticker, or renew one on change of ownership.

Operator certification for specialist equipment such as crane and EWP use is in addition to requirements of this Code.

KiwiRail maintains a register of personnel holding KiwiRail qualifications. Details for preparing a training and competency syllabus are in [Appendix H. Training and competency syllabus](#).

3.20 Incidents

After a significant incident, or whenever KiwiRail advises, an HRV may need to be held or 'impounded' until a full engineering assessment of any relevant matter can be supervised by KiwiRail. This is to investigate any matters in relation to vehicle performance and the ability to accept incident-related vehicles back onto the Network.

Any incidents must be reported immediately to KiwiRail using the IRIS system.

4. Approvals

4.1 Type approval

Type approval must be obtained for any:

- new HRV design
- HRVs that have been modified since receiving type approval
- Imported HRVs unless specific exemption is granted.

The vehicle owner, supported by the Certifying Engineer, can apply to KiwiRail for type approval acceptance once the requirements of section 4.2 [New, modified or imported vehicle](#) are satisfied. KiwiRail will review the application and complete the Entry Approval Checksheet but relies on the Certifying Engineer to check that the vehicle complies with the engineering aspects of this Code. KiwiRail type approval acceptance is confirmed by correspondence.

Once a design is approved, additional vehicles that are functionally identical to the approved design automatically have type approval subject to the Certifying Engineer's agreement as documented on the Type Approval Certificate. For example, a series of HRVs using a common base vehicle and identical Hi-Rail equipment, but with minor variations in on-board equipment and fittings, could share type approval at the discretion of the Certifying Engineer.

Variations in on-board equipment that could be expected to result in changes to load distribution, braking performance etc. will require new type approval. Modification to the design or equipment, even if performance should not change, will require the vehicle to be re-assessed for type approval, re-inspected to the Loco 160A Hi-Rail Equipment Inspection checksheet or Loco 710 Entry Approval checksheet depending on the extent of the modification and a new Loco 155B sticker issued once compliance is established. If in doubt, contact KiwiRail.

Note: a registered Heavy Vehicle Specialist Certifier must assess the adequacy and effect of the attachment of Hi-Rail equipment to the vehicle chassis, and the compliance of the attached equipment with current road vehicle standards. Proof of compliance is required before a vehicle testing station can issue a road Certificate of Fitness. This assessment is outside of the scope of this Code, but copies of specialist certification are to be provided with the Type Approval Certificate ([Appendix E Type approval certification](#)) and be included in the operators manual ([Appendix G. Manuals](#)).

4.2 New, modified or imported vehicle

This section applies to new vehicles not yet approved by KiwiRail for use on the Network, previously approved HRVs that have been modified, and HRVs imported into New Zealand.

The vehicle owner must provide the following evidence to achieve KiwiRail type approval for a new, modified or imported vehicle:

1. Type Certification by Certifying Engineer that design, build and testing of vehicle confirms full compliance to KiwiRail requirements and to all relevant regulatory requirements. See [Appendix E Type approval certification](#) for the requirements of a Certifying Engineer's Type Approval Certification.
2. Risk management to NRSS/4 across design, maintenance and operation, including all hazard mitigations and residual risks acknowledged and accepted. Operator and sample crew are to sign-off final risk assessment. See [Appendix F. Risk management](#) for the requirements of a Risk Assessment.
3. Manuals covering operating and maintenance including all required mitigations from the risk assessment. See [Appendix G. Manuals](#) for the manual requirements.
4. Training and competency assessment syllabus including all required mitigations from the risk assessment. See [Appendix H. Training and competency syllabus](#) for the requirements of Training and Competency. Note that this material will be attached to the operating manual.

Imported vehicles may need to have some (or all) manual and training material 'reverse engineered' if adequate information is not otherwise available.



Once the above requirements are satisfied, the vehicle is processed according to periodic inspection requirements of section 5 [Periodic inspection process](#).

4.3 Buy (change in ownership) or hire vehicle already approved for NZ

KiwiRail needs evidence that a new owner knows how to safely operate the HRV and recognises the risks associated with the vehicle. The operator must provide the following evidence to KiwiRail:

1. manual(s), including Type Certification (as per 4.2 [New, modified or imported vehicle](#) 1 and 3)
2. endorsement of the risk assessment to NRSS/4. Alternative mitigations and operating restrictions may be put in place by the new operator. Operator management and sample crew are to countersign the current risk assessment including any amendments
3. evidence of crew training and competency assessments. Changes to the original training material put in place may be required by the new operator.

Where the new owner already operates HRVs of exactly the same type, KiwiRail must still be advised of the change in ownership for each vehicle.

Once the above requirements are satisfied, the vehicle is processed according to periodic inspection requirements of section 5 [Periodic inspection process](#).

5. Periodic inspection process

After an HRV has achieved entry approval, and periodically at 6 monthly intervals, KiwiRail will:

1. audit compliance and condition of the HRV using the customer's pre-inspected Loco 160A Hi-Rail Equipment Inspection Checksheet (see [Appendix D. Checksheets](#)), then,
2. check that the vehicle manual is present
3. check for evidence that the minimum required maintenance has been undertaken
4. check for evidence of a fault and repair booking system
5. for a new vehicle, or where a vehicle has changed owner or operator, check evidence of training signed by trainer and trainee, and endorsement of risk management.
6. Subject to the evidence being satisfactory, issue a Loco 155B (and Tunnel Suitable sticker as appropriate) and apply a unique identity number to all HRVs (if not already allocated). This forms the periodic inspection process.

6. Common design requirements

6.1 Profile & Height

All parts of the vehicle and its secured load and equipment must be within the limits of the standard loading gauge (drawing 13090429). This drawing is included in Appendix B of NRSS/6. Further height restrictions apply in electrified areas.

When a vehicle is within a rail corridor but is NOT on rail or on a public road it is restricted to a height of 3.2 m when near live traction overhead wires. Any HRV that is higher than 3.2 m or able to change its shape to more than 3.2 m high will be prohibited from electrified rail corridors or subjected to operating restrictions as described below.

Shape changing vehicles are HRVs that can change profile such as excavators, tipper trucks and vehicles fitted with cranes or EWP's. Shape changing vehicles which are used under (isolated and earthed) overhead wires must have their reach restricted or other restrictions applied so that they cannot strike and damage the overhead wires when travelling or working.

For pantographs see 7.2 [Pantographs](#).

HRV description	Restrictions in electrified areas
Height less than 3.2m high and not shape changing	No restriction
Shape changing and fitted with either a chain restraint or lock-out device that prevents any part of the vehicle exceeding 3.2m high when in use.	No restriction when restrictor in use. Restrictor or lock-out use can be waived within a work site under the authority of the Person In Charge provided that a safety observer monitors the operation of the equipment and appropriate authorisations are issued.
Shape changing and NOT fitted with either a chain restraint or lock-out device that prevents any part of the vehicle exceeding 3.2m when in use.	Restricted or prohibited in electrified areas. See below for details.
Higher than 3.2 m when stowed whether fixed shape or shape changing.	Restricted or prohibited in electrified areas. See below for details.

Vehicles that are shown as restricted or prohibited in electrified areas are prohibited unless specific written permissions have been granted by a KiwiRail regional or head office manager responsible for traction engineering. Permission will:

- specify track lengths where the vehicle may (or may not) operate
- state whether the authority is permanent or give dates of validity
- list any restrictions (such as operator qualification) and the supervision required.

A copy of the written permission must be included in the operator's manual, which must include an alert on the safety page that restrictions apply. An alert must also be displayed in the cab stating, "This machine is restricted in electrified areas. Check requirements."

Vehicles that are prohibited from electrified areas must have signage in the cab stating, "This machine not to be used in an electrified area". This message must also appear on the safety page of the operator's manual.

All loads and equipment must be secured against movement in transit, as required by the Land Transport Act 1998, and detailed in The Official New Zealand Truck Loading Code. This includes crane jibs and similar parts.

Note: The dimensions of the standard loading gauge allow for the throw on curves of a conventional railway wagon with a rail wheelbase of up to 12.192 m and end overhang proportions equivalent to a UK wagon. This definition is not easily applied to a typical HRV.



For a HRV, the following relationship can be used to check compliance. Note that X and Y are in metres, and in some cases the front overhang will be more than the rear overhang. Use the largest overhang.

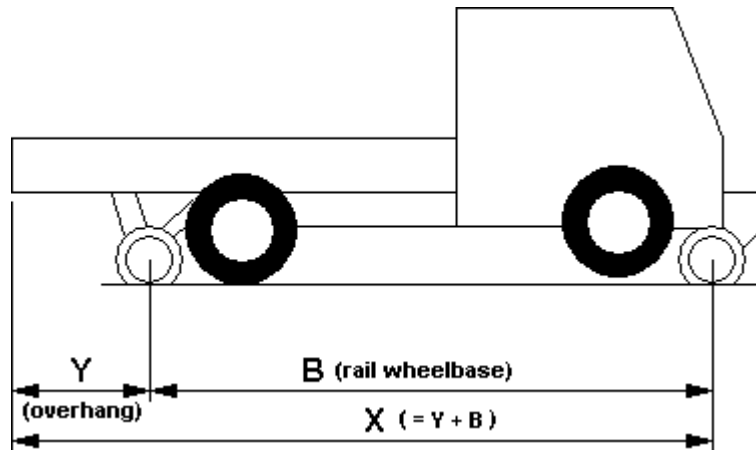

Appendix B includes a chart (Figure 2) that can be used to determine the maximum overhang beyond the rail wheels that complies with this requirement. Vehicles with longer wheelbase or greater end overhang are subject to further restrictions on size and must be referred to KiwiRail for assessment.

6.2 HRV drive systems

Drive systems using road tyres driving directly onto rail wheels are prohibited.

6.3 Attachment to chassis and structural modifications

Note:

For a HRV to be road worthy a registered Heavy Vehicle Specialist Certifier must assess the adequacy and effect of the attachment of Hi-Rail equipment to the vehicle chassis, and the compliance of the attached equipment with current road vehicle standards. Proof of compliance is required before a vehicle testing station can issue a road Certificate of Fitness. This assessment is outside of the scope of this Code.

1. All chassis and structural modifications to the vehicle must be approved by a CPEng Engineer, or a registered Heavy Vehicle Specialist Certifier.
2. Where these modifications affect the chassis or safety systems of the vehicle, they must meet the requirements of the Land Transport Rules and, where required, be approved by a registered Heavy Vehicle Specialist Certifier. This includes the fitting of Hi-Rail equipment and its effect on the vehicle structure in both road and rail modes.
3. A copy of the Certificate approving any modifications forms part of the vehicle manual and must be on board the vehicle at all times.
4. Any hi-railed road vehicle presented for inspection to allow its use on the Network must have a certificate of fitness or warrant of fitness issued to it while in its Hi-Rail converted form.

6.4 Wheel back-to-back dimensions

The back-to-back dimensions between inside faces of wheels or tyres on a wheelset must be between 996 mm and 999 mm, measured at the lowest point, with the vehicle on the track. Gauge 50103060 will be used to check this dimension (see [Appendix C. Drawings](#)).

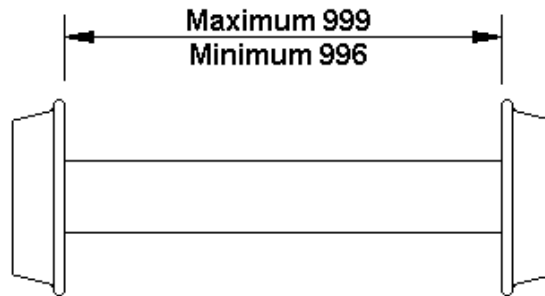

6.5 Wheel profiles

Wheel wear must be within limits when measured with Wheel Wear Gauge 50107007 (see [Appendix C. Drawings](#)).

Wheel profiles must be to a National Rail System standard. Modified Heumann profile wheels with a tread conicity of 1 in 20 are used on the National Rail System. The recommended profile for HRVs is E1 on drawing 7604/15. This drawing is included in Appendix A of NRSS/6. Gauge 50107551 will be used to measure this profile (see [Appendix C. Drawings](#)).

6.6 Standard wheels

The following wheels are currently in use on HRVs in New Zealand:

- Harsco HR2000. Available from Harsco Australia.
- 50107319
- 50102483
- 50100522

Wheels in the 5010 series (LIV wheels) are available from KiwiRail.

The use of one of these wheel designs is recommended. Other wheel designs must be approved by KiwiRail before they can be used on the Network.

6.7 Wheel nuts

Hi-Rail wheels are to be secured using cone-lock nuts. Nyloc nuts must not be used. Wheel nuts must be marked in the secured position for easy visual inspection.

6.8 Maximum axle load

1. The maximum axle load must not exceed 16,000 kg.
2. The P/D ratio must not exceed the values tabulated below where P is the axle load in kg and D is the wheel tread diameter in mm.

Diameter of fully worn wheel	Vehicle characteristics	Maximum P/D in travel mode
Less than 270 mm	All	15
Greater than or equal to 270 mm	Load distribution assured in travel mode, and steady load without shock loads from machine operation in working mode such as might be caused by excavating, loading or discharge operations, unless specifically permitted in the vehicle certification.	27

Greater than or equal to 270 mm	All other cases.	20
---------------------------------	------------------	----

6.9 Side-to-side wheel load balance

For a general-purpose HRV, side-to-side wheel load imbalance must be no more than 20% of the lighter wheel, on level track. The method of testing this is described in Appendix A.

Charts for calculating Out of Balance are included as Figure 3 and Figure 4 in [Appendix B. Charts](#).

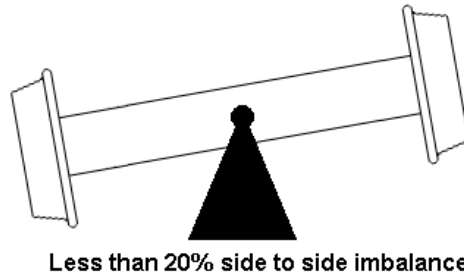

For specialist hi-rail plant, side-to-side wheel load imbalance must be no more than 30% of the lighter wheel, on level track. Where side-to-side wheel load imbalance exceeds 20%, track speed is restricted to 25 km/h, and this is to be noted in the special conditions of the type approval.

6.10 Twist negotiation

No rail wheel may lose its entire vertical load during a 37 mm elevation of any other wheel based on a 4.28 metre wheelbase. A chart giving equivalent twist elevation for other wheelbases is included as Figure 5 in [Appendix B. Charts](#).

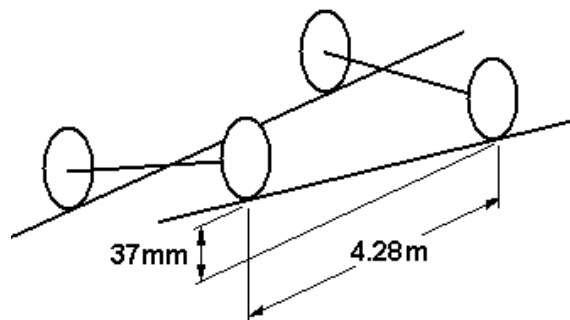

6.11 Loads on rubber tyres

Loads on rubber tyres in contact with the rail must not exceed the manufacturer's load rating under any condition of loading. It is recommended that at maximum vehicle load, the maximum load on the tyre is limited to 90% of its load rating as a dual. It is also necessary to ensure that sufficient load is carried on the tyres to provide adequate grip for traction and braking.

Where practical, set up and testing should be done using both new and fully worn rail wheels and new and fully worn rubber tyres, to ensure that the vehicle will remain compliant throughout the wear life of these components.

Tyres must be type approved for Hi-Rail use with the vehicle. Experience has shown that tyres with the heaviest available ply rating must be used, and that a ribbed tread pattern is preferable to a block pattern as block pattern tyres tend to lose chunks of tread in Hi-Rail operation.

The tyres approved for the vehicle and their "on rail" pressures must be defined in the vehicle manual.

If different tyres are to be approved for use under a vehicle, the vehicle and these different tyres must be re-assessed for compliance by KiwiRail and the vehicle manual updated and re-issued with a new approval.

6.12 Insulation

All HRVs must be insulated for track circuits, that is, there must not be a short-circuit between the rails through any part of the vehicle. When tested with a 500V "Megger", the minimum insulation resistance between the rail wheel and the chassis on insulated wheels shall be 1000 ohms.

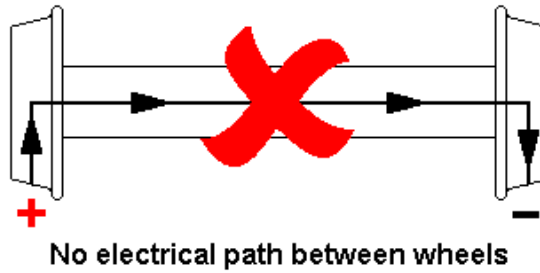

6.13 Earth path

All HRVs must be provided with an "earth path" to the rail for working in electrified areas.

Earth cabling is to have a cross-sectional area of 35 mm². The "earth path" may include a spark gap. Spark gap units must be approved by KiwiRail and tested after installation.

There are additional requirements for vehicles equipped with pantographs - see section 7.2 [Pantographs](#)).

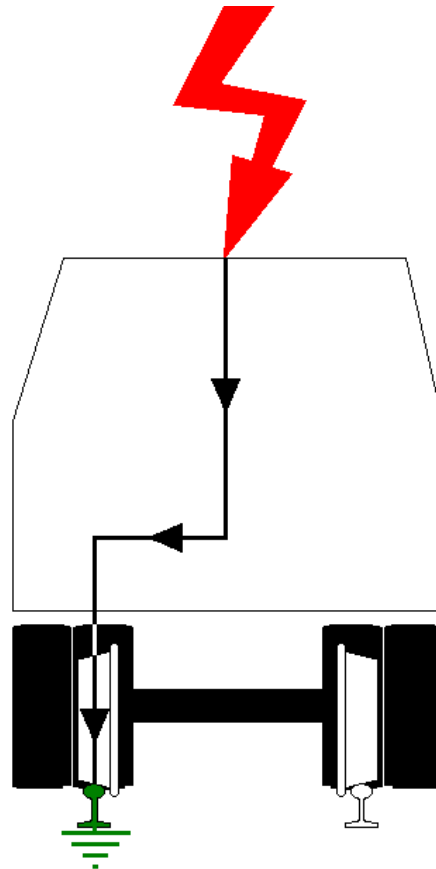

6.14 Stability

See also section 6.28 [Cranes and elevating work platforms](#).

HRVs must be stable when travelling on rail. It must be demonstrated by calculation or physical test that the vehicle (in all conditions of load) will not tip over under a lateral acceleration of 0.3 g when on level track

HRVs fitted with cranes, elevating work platforms, tippers and similar devices must be stable under all combinations of load and extension allowed. This may require the use of supplementary stability devices such as outriggers or rail clamps.

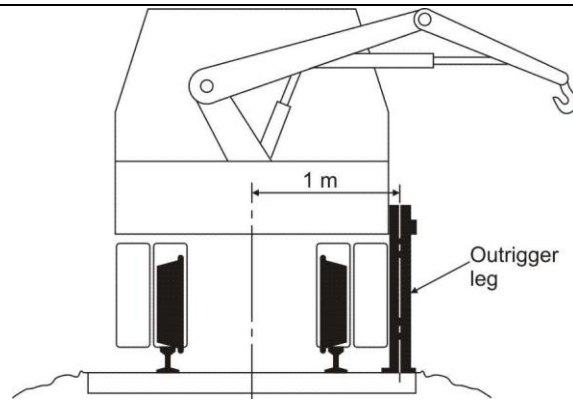

Where outrigger legs are required for safe operation, it is recommended that the feet make ground contact at a point no more than one metre from the centreline of the vehicle. This will allow the feet to bear on the compacted track formation within the sleeper length, rather than on the loose outer ballast, which may not be suitable for carrying this type of load. If it is necessary for outrigger legs to make ground contact outside of the sleeper length, the design should be reviewed with KiwiRail.

Where rail clamps are required for safe operation, these must be approved by KiwiRail.

Where outrigger legs or rail clamps are required for safe operation, this must be clearly identified on the equipment and in the vehicle manual. If the requirement to use outrigger legs or rail clamps depends on the combination of load and extension, then this information must be clearly documented and displayed in the form of an easily understood graph or table.

6.15 Warning lights

All HRVs must be fitted with a rotating amber light or an amber flashing strobe light for use while on track. The light must not be obscured at a distance of 5 m from the front or back of the vehicle and must be visible for at least 150 m. For excavators, the light(s) must be visible from the front or back direction while travelling slewed in hi-rail mode.

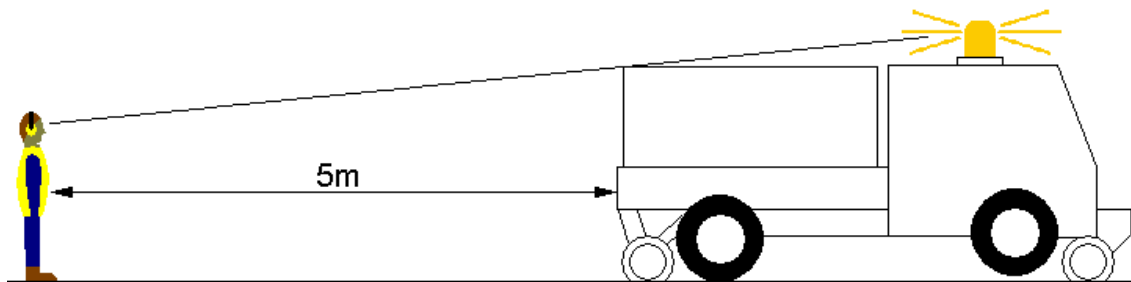

6.16 Hazard lights

All road capable HRVs must be fitted with hazard lights.

When travelling in hi-rail mode, two white lights must be displayed forward and two red lights displayed rearward.

6.17 Reversing beeper

All road-capable HRVs must be fitted with reversing beepers. The emitted sound must be directional and appropriate for night time use in suburban areas.

6.18 Horn

All HRVs must be fitted with an air horn with a minimum of 110 dB(A) sound pressure level, measured at one metre.

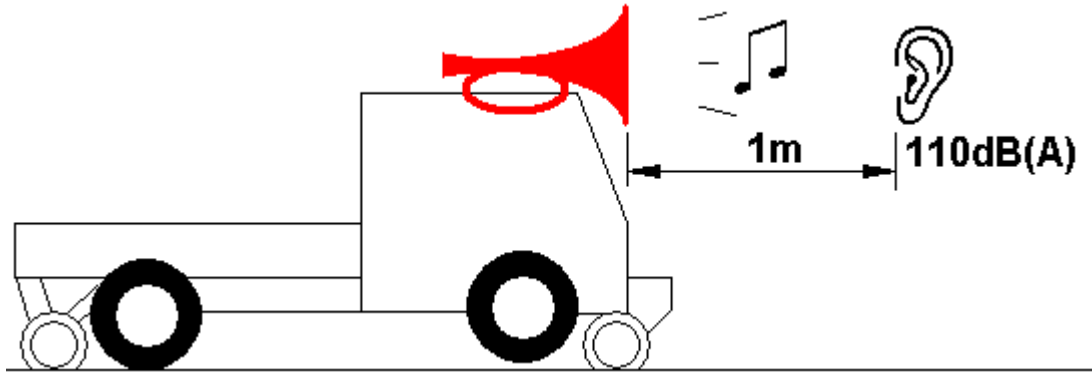

6.19 Train Control radio

All HRVs must be equipped with radio receiving and transmitting equipment allowing communication with the KiwiRail Train Controllers and with other trains on the Network.

This equipment must be specified, installed and maintained in accordance with KiwiRail Code Supplement: Signals, Telecommunications, Electrical (STE) S/RA003 "Rail Vehicle Operators – Radio Equipment".

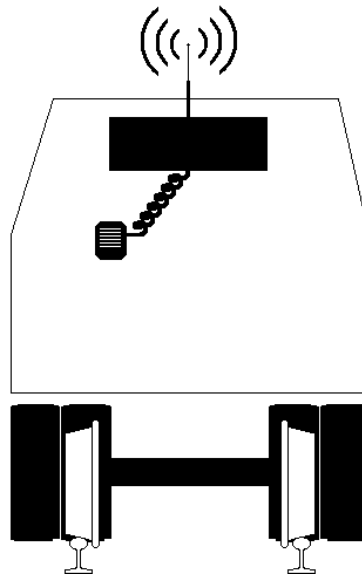

6.20 Maximum speed

The maximum operating speed for HRVs is 50 km/h.



Type approval testing for a new or modified HRV must be carried out at speeds up to 20% above the authorised maximum operating speed depending on vehicle capabilities.

Maximum rated speed must be determined for each HRV type and be clearly stated on the Type Approval Certificate and in the vehicle manual.

Maximum speed is to be displayed prominently on the vehicle dashboard using the following words:

"Maximum speed on rail is **00 km/h**"

When the maximum speed is 25 km/h or less, the requirements above must also be displayed on the exterior of the cab door, or control station.

6.21 Speedometer

All new HRVs capable of exceeding their maximum rated speed must be fitted with a speedometer or some other means of indicating when maximum permitted speed has been reached.

Where a speedometer is required and the vehicle drive system makes it either inoperative or inaccurate, it is permissible to mark a working speedometer or rev counter with the maximum speed calibrated with a radar gun. 10 km/h is also to be marked. Any speed calibration must be witnessed by the KiwiRail inspector.

6.22 Brake performance on rail

All new HRVs must be fitted with brakes that operate on rail on at least four wheels. Braked wheels can be the flanged rail wheels or the road wheels in rail contact or any combination of these.

1. At least one end must have brakes acting directly to the axle, or both wheels. It is preferred that both ends have brakes acting directly on the axles or individual wheels; however, one end may have brakes acting through a transmission system (chain final drive etc.).
2. Brake systems that use the same retardation or control method on more than one axle must be configured so that a failure that affects one axle does not cause such loss of braking from the other axle that the vehicle cannot be brought to a standstill. For example:
 - Hydraulic brake lines may be split or duplicated
 - PLCs or other electrical control systems must fail safe.
3. Stopping distance and parking brake requirements must be met without any contribution from the road tyres i.e. braking may not rely on the friction drive from the road tyres (except LIVs).
4. HRVs with rubber tyres that drive directly onto the rail and built with only two braked wheels may not be certified or operated.
5. Existing hi-railed excavators and other vehicles with self-laying tracks may rely on hydraulic drive retardation for braking on less than four wheels provided that the operator can ground the vehicle by retracting the hi-rail equipment from the cab to stop in an emergency. The hi-rail equipment must be able to be readily retracted directly without any sequential operations i.e. A+B together is acceptable, A then B or A then B+C together is not acceptable.

If certified prior to August 2016 (issue 4 of this Code), existing hi-railed excavators and other vehicles with self-laying tracks that rely on hydraulic drive retardation for braking on less than four wheels must be either:

- (Preferably) fitted with brakes that operate on rail on at least four wheels, or
 - Restricted to operation on gradients of less than 1 in 90 with appropriate warnings displayed in the cab.
6. All HRVs with less than four directly braked rail wheels are limited to 25 km/h.
 7. All HRVs must stop within 22 metres from 25km/h. Testing is to be performed on level, dry track, both empty and fully loaded.
 8. All new Light HRVs must stop within 50 m from 50 km/h. Testing is to be performed on level, dry track, both empty and fully loaded.
 9. Heavy HRVs (over 5t tare) and existing Light HRVs with only two braked wheels must stop within 85 m from 50 km/h. Testing is to be performed on level, dry track, both empty and fully loaded.

10. Braking performance at the speed required above must be tested and recorded on the Entry Approval Checksheet.

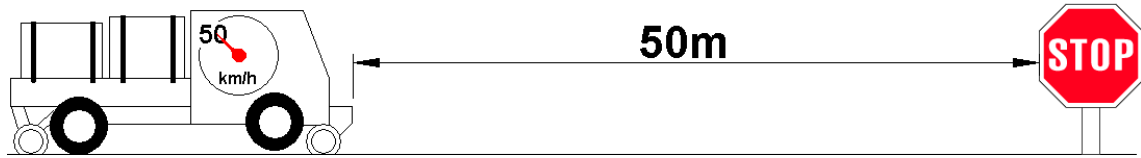
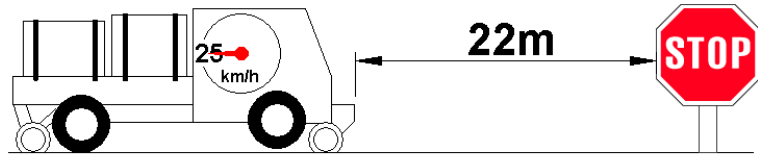

6.23 Parking brake

The gradient on which parking brakes must hold is changing and is being phased-in for all HRVs as follows.

6.23.1 Existing HRVs

Except for hydraulically retarded hi-railed excavators and other vehicles with self-laying tracks restricted to 1 in 90 gradients (see 6.22 §5), the following requirements apply to all existing HRVs until 1 February 2025. New vehicles shall not be designed to this performance standard.

HRVs must be fitted with a parking brake that will hold the vehicle stationary indefinitely on rail on a slope of at least 1 in 33 when fully fuelled and loaded in the most unfavourable loading condition and vehicle orientation. Parking brake design must account for low adhesion (rail wheel to rail coefficient of friction 0.12).

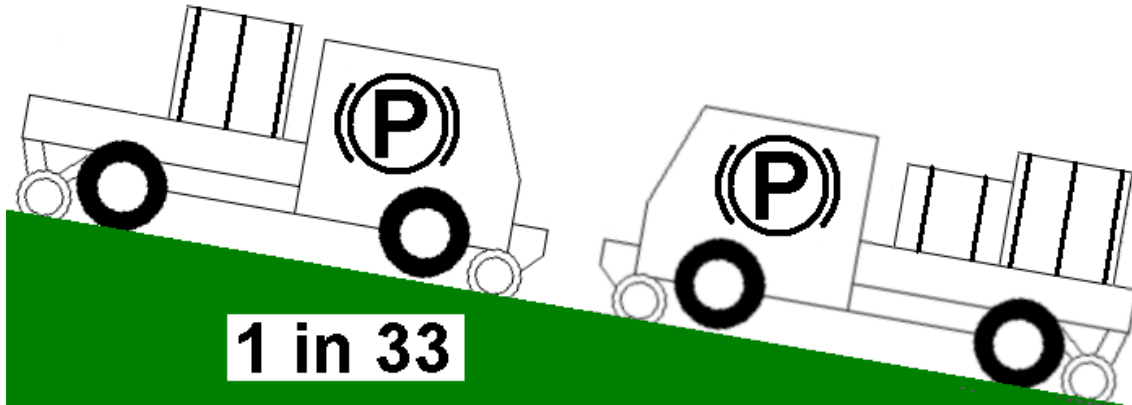

This can be tested on level track by ensuring that the park brake will restrain a force equal to:

$$\frac{\text{Vehicle weight}}{30}$$

applied in either direction.

Note: This includes a 10% allowance for load transfer on a grade.

The parking brake must operate in such a way as to prevent runaway of the vehicle during all stages of the transfer of the vehicle from road to rail and from rail to road including on a grade of 1 in 33.

6.23.2 CRL Grade Suitable, new HRVs, and changed requirement for all HRVs

The following requirements apply to:

- All CRL Grade Suitable HRVs from the issue date of Issue 5 of this Code.
- All new HRVs from the issue date of Issue 5 of this Code.
- All HRVs from 1 February 2025 – except where identified as Grade Restricted vehicles by sticker alongside the Loco 155B (see 3.7.2)

HRVs must be fitted with a parking brake that will hold the vehicle stationary indefinitely on rail on a slope of at least 1 in 30 when fully fuelled and loaded in the most unfavourable loading condition and vehicle orientation. Parking brake design must account for low adhesion (rail wheel to rail coefficient of friction 0.12).

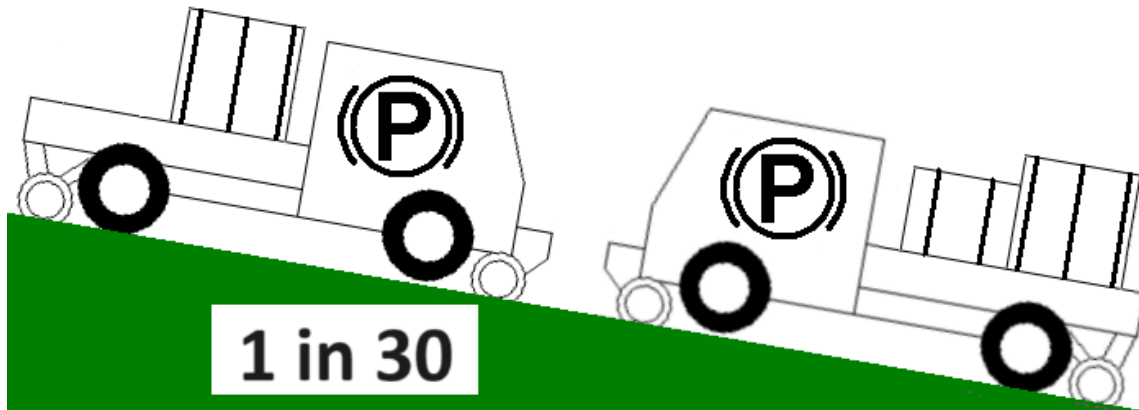

This can be tested on level track by ensuring that the park brake will restrain a force equal to:

$$\frac{\text{Vehicle weight}}{27}$$

applied in either direction. The pulling gear must be parallel to the track.

Note: This includes a 10% allowance for load transfer on a grade.

The parking brake must operate in such a way as to prevent runaway of the vehicle during all stages of the transfer of the vehicle from road to rail and from rail to road including on a grade of 1 in 30.

6.23.3 General park brake requirements

Park brakes must be intuitive to apply so that they can be readily applied in an emergency. A single step process is preferred.

Park brakes must be designed to fail safe so that any failure in the brake system results in the brake applying automatically. Examples include systems applied by spring force and released by air or hydraulic pressure.

1. Wherever possible, eg, on hydraulic drive vehicles, the park brake must be interlocked with the drive system so that the park brake will apply automatically when the vehicle is standing.
2. All new HRVs with friction drive must have a park brake which acts directly on the rail wheels and does not involve the friction drive system.
3. All HRVs with direct drive (road tyres which drive directly onto the rail) may use the vehicle road park brake as part of this requirement provided that no runaway is possible at every stage of transfer of the vehicle from road to rail and from rail to road.

Existing excavators, crawler carriers and other vehicles with self-laying tracks that do not have a park brake must be grounded (their self-laying tracks and boom/attachments) whenever the operator leaves the cabin and the operator must not leave the cabin at any time while the machine is hi-railed. This requirement must be included in the vehicle manual and displayed in the operator's cab. As an example suitable wording is:

"This machine must be grounded before operator leaves the cab.

Operator must not leave the cab at any time while the machine is hi-railed"

Design Note

Park brakes should be as close as possible to the rail wheels in the drive system eg, on the same shaft as the wheels rather than the motor.

Information – hydrostatic drive as park brake

Hydrostatic drive systems do not provide enough resistance to prevent a vehicle running away on a grade. Tests conducted after a runaway incident have showed that the hydraulic drive would hold the vehicle for only a limited time before starting to creep and eventually breaking away.

6.24 Brakes – all types

Maintenance and test requirements for service and park brakes must be included in the vehicle manual and must include any linkage that is between the brake actuator and rail wheels.

Vehicles using hydraulic actuators to apply or release the brakes must include hydraulic oil condition in the vehicle's documented maintenance regime.

Information – hydraulic oil

Park brakes relying on hydraulic oil pressure for release have failed overseas due to contaminated oil blocking hydraulic valves. Hydraulic oil condition must be part of a vehicle's maintenance regime.

6.25 HRV safety systems

Front mounted Hi-Rail equipment must be fitted with a manually operated locking pin that prevents the rail wheels from lowering when the vehicle is operating on road.

Operation of the following Hi-Rail equipment must be controlled by at least two separate controls (e.g. "master power supply" and "direction"). These controls must require the operator to use both hands to perform the transfer. This is to prevent accidental operation of the Hi-rail equipment while moving, such as:

1. deployment and retraction of hi-rail system*
2. any shape changing features such as slewing, tipping and raising devices that will be out of clearance gauge and potentially unstable.

*See also section 6.22 requirements when easy retraction is required in an emergency.

Hydraulic systems powered from the vehicle PTO (power take-off) are preferred over electric or electric-hydraulic systems. Where electrical systems are used, special care is required to ensure that they are thoroughly protected from water ingress. Experience has shown that the harsh rail operating environment will quickly degrade the performance of even externally rated electrical housings. Any such housing must be under cover.

Hi-Rail equipment must be latched in place when in rail mode independent of the system used to deploy it. Examples of suitable solutions include over-centre mechanisms and hydraulic anti-burst valves. (Ensure that engine failure on an excavator with anti-burst does not prevent the machine lowering itself onto the ground).

Provision must be made for the safe removal of the vehicle if it breaks down while in rail mode. This includes provision for towing and off-tracking. Examples of suitable solutions include the ability to release automatically applied brakes and a manual pump to retract hydraulically applied hi-rail equipment.

6.26 Pressurised systems

New HRVs must meet the requirements of this section to qualify as Tunnel Suitable. To demonstrate tunnel suitability, the pressurised systems of existing HRVs may require repair in order to achieve a Tunnel Suitable endorsement at the 155B inspection.

The design, construction and maintenance of pressurised systems, both hydraulic and pneumatic, must:

1. incorporate a suitable and adequate relief system
2. provide adequate means for the control of generated heat



3. minimise the types of movement in hoses that can significantly reduce service life, such as bending, twisting, stretching and vibration beyond the hose’s reasonable capability, for example, by incorporating elbows, rotating fittings and clamps
4. protect hoses from the risk of impact and crushing

NOTE

Hydraulic hose life is often determined by the internal failure of the reinforcement, mainly from fatigue caused by pressure pulsations or hose flexing. Unlike external damage, internal hose fatigue failure cannot be inspected for or reliably predicted. The often used ratio of static burst pressure to operating pressure does not address fatigue degradation.

5. incorporate control and operating functions that provide adequate protection from malfunction or uncontrolled action due to pressure hose, pipe or fitting failure.
Note: It is recommended to follow an industry standard such as SAE J1273 – Recommended practices for hydraulic hose assemblies.
6. specify in the vehicle manual the service life of hydraulic hoses in normal use as 15 years or 10 years according to the following table:

	15 years (Premium hoses)	10 years
First period	Hoses less than 15 years old, and: <ol style="list-style-type: none"> 1. with OEM markings on the hoses, or 2. whose type has been fatigue tested, evidenced by OEM statement, or 3. have synthetic reinforcing evidenced by markings on the hoses. 	Hoses not OEM and no evidence of fatigue testing.
Subsequent periods	Replacement hoses with evidence of replacement, such as, vehicle specific supplier’s invoice, work order, or Certifier’s statement, and <ol style="list-style-type: none"> 1. with OEM markings on the hoses, or 2. whose type has been fatigue tested, evidenced by OEM statement, or 3. have synthetic reinforcing evidenced by markings on the hoses. 	Replacement hoses not OEM and no evidence of fatigue testing. Evidence of replacement: vehicle specific supplier’s invoice, work order, or Certifier’s statement.

6.27 Mechanical systems

All mechanical systems must be of adequate design to meet all possible overload requirements throughout the term of the equipment design life, including those of impact (both internal and external), shock, and vibration.

6.28 Cranes and elevating work platforms

Refer to section 7.1 [Cranes and elevating work platforms \(EWP\)](#)

6.29 Machine controls

Electronic controls, software and electrical control systems present the difficulty of verifying and validating their safety integrity, particularly when using components or sub-systems of unknown individual safety integrity, and considering the number of components in an end-to-end system, ie, from crew control input to machine physical output.



The use of PLCs, customised software and associated system elements or components to control safety critical functions must be fully supported by best practice assessments and preferably independent verification and validation. KiwiRail would also need to be assured of back-up for the software and control system(s).

KiwiRail's preference and expectation is that such systems are fail-safe, have manual work-arounds and are therefore non-critical if involved in safety functions.

All controls must be of robust construction and, where required, waterproof.

All controls must be positioned and protected to prevent accidental operation.

Controls must be positioned in a logical sequence.

All controls must be clearly marked to show their function in permanent legible letters or symbols. Any words must be in NZ English.

Arrows on or beside the appropriate control should indicate movements of arms, beams, hoists, etc.

All controls must be of the "dead-man" type that automatically return to the neutral or off position when they are released or, alternatively, all controls may be over-ridden by an emergency stop.

An emergency stop control, which will cut off power to all systems, must be provided at each operator position. This stop control must be placed in a prominent position and be coloured red.

Where required, interlocks must be provided to ensure that contrary operations or movements do not occur.

For pantographs, see 7.2 [Pantographs](#).

6.30 Interlocks

Interlocked systems must be configured so that they do not prevent the machine being safely retrieved, stowed and removed from rail. They should not cause the machine to "freeze".

Interlocks must be fail-safe. If a component fails (cable, micro-switch etc.) the system must fail to a safe condition, and should allow the machine to return to a safer state.

The vehicle manual is to contain instructions on how to maintain sensors and test that interlocks are operating correctly.

Information – Interlock failure examples

Runaways have occurred when faulty interlocks have captured friction drive vehicles in transition between road and rail modes and the operator has been unable to complete on-tracking or retract the hi-rail equipment.

Out of adjustment EWP interlocks have sensed an unsafe state and prevented any movement at all, freezing the vehicle in extended mode blocking the track.

6.31 Fire safety

WARNING

HRV fires in tunnels or on bridges are particularly hazardous because of the limited ability to fight a fire and escape from it. Fires in tunnels can grow dangerously fast. Rescue from outside is often not possible.

Vehicle fires can have any of a number of causes, but electrical issues dominate, followed by engine and fluid issues. The overwhelming non-collision vehicle fire causes relate to equipment faults and malfunction, poor maintenance and lack of cleanliness.

The following rules are aimed to achieve a high standard of fire hardening in new HRVs by preserving the integrity built in by the OEM while also addressing risks added by changes to the vehicle and systems added to it. Satisfying these rules may not be all that is needed to assure safety. Different approaches are possible but need to be

justified. The rules apply to any OEM electrical or fluid system that has been modified or any additional non-OEM system that has been added. Section 6.32 provides guidelines on applying fire safety rules.

Fire defences must be sustained by a high standard of vehicle maintenance, servicing and cleaning, and a high standard of "housekeeping" during normal operation.

New HRVs must meet the requirements in this section to qualify as "tunnel suitable" and display an endorsement sticker in addition to the Loco 155B. Existing HRVs must be retrofitted with all of the features in the Firefighting section below and all of the features marked # in sections Electrical protection and Fluid containment in order to achieve a tunnel suitability endorsement at the 155B inspection (i.e. all Firefighting features, and some of the Electrical protection features of the Fire hardening section below).

HRVs prohibited entering tunnels longer than 200m must:

- Have an alert on the safety page in the operator's manual.
- Display a Tunnel Restricted decal on the windscreen.

Auxiliary engines or self-powered equipment must also meet the requirements in this section if the parent vehicle is to qualify as "tunnel suitable". Safety systems must be integrated with those of the parent vehicle systems where practicable. For example, a self-contained generator mounted on a truck must have provision for fire fighting and be protected by e-stops. Operation of any e-stop should shut down both the parent vehicle and the auxiliary unit.

Fire safety equipment will only ever be fully tested in a real emergency so it is important that vehicle systems are designed to be obvious and simple to access and operate in conditions that may be dark, shadowed, noisy, or disorienting. Operator's manuals (Appendix G) and Training and Competency Syllabuses (Appendix H) must clearly illustrate the systems provided and provide familiarity with them.

6.31.1 Fire fighting

All the following items are required for new HRVs and existing HRVs to achieve tunnel suitability.

1. Portable fire extinguishers must be provided as follows:
 - a) one small extinguisher in the cab within reach of the driver
 - b) external extinguishers located for easy stowage, rapid removal as necessary, and security from interference
 - c) at least one external extinguisher positioned for an engine bay fire.
 - d) for road-based HRVs, at least three 9 kg fire extinguishers, unless it can be shown this is impracticable, with at least one extinguisher at the front of each vehicle when on-tracked, and behind the rear axle of the HRV at all times
 - e) for road-capable HRVs, the mounting of the front extinguisher container, including loaded extinguisher, must be rated for a 20g horizontal forward impact loading. The container with extinguisher must remain attached but may deform.
 - f) for construction machinery based HRVs, at least two 9 kg fire extinguishers, unless it can be shown that this is impracticable, with at least one extinguisher located to allow rapid connection to an engine fire, and access to each end of the machine when in a narrow tunnel.

Extinguishers must be easily accessible in an emergency. Locating extinguishers at each end of a vehicle during travel and work in a tunnel ensures that at least one will always be accessible. Extinguishers may be stored away from their operating location but must be in place, unlocked and directly accessible at worksites.

Design note

When choosing extinguisher size take into account: ease of retrieval, the ability to physically hold the extinguisher up to a fire fighting point (such as a porthole), and the ability to provide an obvious storage location.

2. Conduits or portholes must be provided to fire risk areas with difficult access (including where it would be dangerous to open access covers or doors). Conduit must:
 - a) be fire protected if in an area that may be exposed to flame, for example, a flame-proof sleeve
 - b) incorporate a nozzle at the internal end to deliver the required spray pattern
 - c) be accompanied by signage for connecting and operating a fire extinguisher.

3. Portable fire extinguishers must:

- a) all be dry powder type so that they can be discharged through access conduits
- b) have discharge hoses to assist access to fires.

4. Automatic Fixed Fire Suppression Systems

HRVs admitted to the network for the first time after 1 July 2016 will be either fitted with an Automatic Fixed Fire Suppression System (AFFSS) in the engine bay or prohibited from entering tunnels longer than 200m. Exceptions may be made for one-off access where alternative measures are in place. AFFSS may be required for existing vehicles, at KiwiRail's discretion, if fire safety cannot be otherwise adequately assured.

AFFSS systems must be robust and reliable and must not cause additional hazard when they discharge in the restricted space of a tunnel. Gas systems are not acceptable. Water mist systems are acceptable.

AFFSS systems must be supplied and installed by an accredited supplier. Selection criteria will consider: media type, capacity, coverage and reliability.

An installation report must be provided that addresses the specific risks of that vehicle. The installation report must include a risk assessment to an internationally recognised fire safety standard.

The Operator's Manual for the vehicle must include:

- A copy of the accreditations and installation certificates for the system.
- A copy of the installation report provided by the installer or a specific document reference to it.
- Inspection and maintenance requirements for the AFFSS. A separate manual is acceptable but routine inspections such as pre-use checks must be included.

HRVs fitted with AFFSS must also comply with all other requirements the Fire Safety section of this code to be rated as "Tunnel Suitable".

⚠ Caution – AFFSS

AFFSS systems are not a remedy for all fires. They have coverage limits, may not extinguish all fires, and fires may reflash. There may still be a need to apply fire extinguishers. Hence the other provisions of this section must still be applied generally as if AFFSS was not fitted.

ⓘ Information – AFFSS

The Code requirement for AFFSS arises from an agreement reached between KiwiRail and WorkSafe NZ (February 2016).

6.31.2 Thermal protection

NOTE

Any surface at more than 150°C is considered a hot surface. The following are always assumed to be hot surfaces and potentially dangerous:

- exhaust manifold and 500 mm of the exhaust system beyond
- turbocharger and 500 mm of exhaust system beyond
- catalytic converter and 300 mm of exhaust system beyond.



Thermal protection (electrical and fluid) on new HRVs

1. Cables, tubes and hoses must not be closer than 100 mm to a hot surface.
2. Cables, tubes and hoses should be routed at least 200 mm away from any hot surfaces >150°C, ideally on the opposite side of any equipment having such component(s).
3. Cables, tubes and hoses between 100 mm and 200 mm from a hot surface must be separated from the hot surface by a metal shield fitted as a barrier against radiated heat.
4. Adequate thermal protection must be provided by a flame-proof or insulated sleeve or jacket over cabling, tubing or hoses.
5. Shielding in barrier or conduit form must allow adequate ventilation to avoid the prolonged heating of any fluid vapours, and must be shaped to avoid the accumulation of debris, oil or grease.

6.31.3 Electrical protection

1. # Electrical system isolation must be provided at least by isolation of the positive pole as close to the battery as possible. Isolation must be possible without lifting the bonnet or opening compartment doors.

Safety critical functions such as back-up lighting and radio may remain connected after e-stop activation long enough for immediate incident response. Any functions that remain connected must be separately fused with the minimum amperage and enclosed in protective tubes in accordance with item 9 of this section below.

E-stops to provide electrical protection must be located in the cab, on the front and at the rear of the machine (for accessibility from either end in a tunnel), at control stations (e.g. platform and ground level controls on EWP's), and anywhere else that risk assessment designates.

E-stops must be located:

- a) For trucks, in the cab, on the front and at the rear of the machine,
- b) For excavators and construction equipment, on the front and at the rear of the machine with the front e-stop positioned for ease of access when leaving the cab.
- c) For small vehicles that do not have extensive modifications and that can be got past in a tunnel such as LIVs, vans and light automotive vehicles, single point manual or e-stop isolation will normally be acceptable unless the vehicle has a high fire load or risk profile.
- d) For EWP's, as per the parent vehicle plus at the EWP platform controls and at the ground level control station.
- e) At control stations outside the vehicle cab e.g. controls for auxiliary equipment and cranes. Where auxiliary engines or self-powered units are fitted operation of any e-stop must shut down both the parent vehicle and the auxiliary unit.
- f) Anywhere else that risk assessment designates.

E-stops must be:

- g) Located for accessibility from either end in a tunnel.
- h) Suitable for use with gloves.
- i) Clearly labelled.
- j) Marked with a nearby patch of reflective material to aid location in the dark (except vehicles certified prior to August 2016, Issue 4 of this code).
- k) Positioned or protected to avoid damage and inadvertent use.

Important: A driver must be able to bring a vehicle safely to a stop, whether on road or rail, if electrical isolation occurs while the vehicle is moving i.e. effects on braking and steering must be checked. Any side effects of electrical isolation must be listed in the Operator's Manual (see Appendix G) and included in the Training and Competency Checklist (see Appendix H).

2. # Battery, generator and power outlet terminals must be covered.
3. The positive cable from the battery must be protected by tube or additional sheathing along its entire circuit length (unless modifying the OEM installation is considered more of a risk).
4. # Every circuit must be adequately protected from over-current and fault currents.
5. Cabling must be adequately rated for its duty, with multi-stranded cable for flexibility and fatigue resistance.
6. Cabling must be protected from mechanical damage including abrasion, cutting, impacting, crushing, and stressing, and it must be clamped and supported against vibration.
7. Cabling is not to be attached to fuel lines. If attached to hydraulic lines, cabling must be low voltage and fused below 10 amp. Above 10 amp fusing, cables must be inside protective tubes.
8. *Not used in this revision.*
9. Control, warning or emergency equipment that is connected to the battery before the isolator must be separately fused with the minimum amperage and enclosed in protective tubes.

6.31.4 Fluid containment

Most of the pressurised fluids in engine bays will burn or "flare off" if sprayed onto hot surfaces (>150°C). This includes glycol coolant mixes as well as brake fluids, lubricating fluids and fuel.

1. # Fluid system shut-down must be achieved by e-stops. Functionality must not be compromised by the fire event itself, and will consider accumulator or statically pressurised parts of the system:
 - a) engine (and engine PTO driven systems)
 - b) electrically driven fluid systems.
2. Fluid lines must be 360° enclosed to contain spray from any burst fault with a product rated as fireproof and, for containment of burst hydraulic hose, possibly of 'woven sleeve' type in the following cases:
 - a) a hydraulic hose is within 2.0 m of the nearest 'hot surface' and in a direct line of sight
 - b) a hydraulic hose is within 750 mm of the nearest 'hot surface' by the shortest possible 'string-line' assessment.
3. Leaking fluid from enclosed fluid lines must drain safely away.
4. Where a large number of hoses are in close proximity to a hot surface, an alternative is to separate such hose groups by an extensive barrier or enclose them within compartment(s) to contain and safely drain spray type leakage in order to achieve an equivalent 360° enclosure.
5. Portable power equipment with fuel tanks and associated fuel containers must have designated safe carriage arrangements that separate them with a fire barrier from the engine exhaust and battery areas of the HRV.

6.32 Guidelines on applying fire safety measures

This section provides guideline examples of how Tunnel Suitable standards can be met for generic vehicle types. There are many differences between actual vehicles so the examples will not cover all cases. Users of these guidelines must still assess each actual vehicle on a case by case basis.

Guidelines on applying fire safety measures

General considerations: ability to retrieve extinguishers both on and off track; access to fires in hard to access areas (portholes or conduit - labelled); access to e-stops and fire extinguishers from both directions and all vehicle configurations when in a tunnel. Where vehicle features such as open doors or drop-down sides make extinguishers less obvious or less accessible add signage to alert users to the extinguisher location.

AFFSS may be required as a retrofit on people carriers (see below) and is otherwise assumed as per code for new machines from July 2016.

Trucks

- One front-mounted 9kg extinguisher. Extinguisher (or extinguisher and housing) may need to be removable on road – if so provide suitable storage for when not in use.
- Conduit or portholes into the engine bay.
- Two extinguishers behind the rear axle, one either side. Preferably 9kg capacity, 4.5kg on smaller vehicles where 9kg will not fit (a smaller extinguisher in a regular location is favoured over a larger extinguisher stored in a less accessible position).
- E-stops front, rear and in the cab. Protect from inadvertent use where necessary so that activation requires deliberate action e.g. in-cab use of protective flaps with consideration of their direction of opening.

Excavators

Ensure sufficient equipment is always accessible e.g. even when the machine is slewed. Position extinguishers etc. so visibility from the cab is not impaired. Protect equipment from damage during machine operation. Portholes to be accessible from ground level.

Small excavators

- 2.5kg extinguisher in the cab.
- 4.5kg extinguisher behind the cab, accessible from ground level.
- A second 4.5kg extinguisher either on the other side behind the cab or mounted on the front of the machine.
- E-stops behind the cab and about the outside front pillar of the cab.
- Porthole into engine bay from the side or rear depending on the machine.
- Porthole into the hydraulic compartment.

Medium excavators

- 2.5kg extinguisher in the cab.
- One 4.5kg extinguisher in the tool-box area (the opposite side from the cab).
- A second 4.5kg extinguisher either in front of the cab or also in the tool-box area.
- One e-stop on the rear of the machine.
- One e-stop mounted about the outside front pillar of the cab.
- Porthole into engine bay from the side or rear depending on the machine.
- Porthole into the hydraulic compartment.

Large excavators

- 2.5kg extinguisher in the cab.
- Two 4.5kg or one 9kg extinguishers in the tool-box area (the opposite side from the cab).
- One 4.5kg extinguisher mounted in front of the cab.
- One e-stop on the right hand side at the rear of the machine.
- One e-stop mounted about the outside front pillar of the cab.
- Porthole into the engine bay from the left side with conduit from the porthole to above radiator level. The conduit must be tested (off-vehicle) to demonstrate that the media flows through it.
- Porthole into the hydraulic compartment.

Crawler carriers

- Two 4.5kg or one 9kg extinguishers mounted on each side of the chassis (beneath the tray).
- Otherwise generally as for large excavators.

Elevating work platforms – truck mounted

- Generally as for the truck or carrying vehicle plus an e-stop in the bucket or platform. An extinguisher is not required in the bucket (given weight and space premiums and relatively low risk location).



Elevating work platforms – boom lift

- Two 4.5kg or 9kg extinguishers mounted on the rear of the machine body, one mounted towards each side. Position to be assessed to avoid damage during slew.
- An extinguisher is not required in the bucket (given weight and space premiums and relatively low risk location).
- E-stop in the bucket and at the ground-level control station. Where OEM devices are already fitted an additional e-stop may be fitted but is not required on the side opposite to the ground-level control station.

People carriers and cabin vehicles

- Cabin vehicles carry crew in a separate space (e.g. to operate inspection equipment). People carriers are vehicles with more than two rows of seats built for the purpose of carrying people (e.g. inspection buses, mini vans).
- Generally as for the parent vehicle.
- E-stop in the passenger space.
- Fire extinguisher(s) in the passenger space.
- Particular attention must be paid to minimising fire load.
- Personnel carriers will likely require AFFSS unless site safety plans will always provide for alternative escape vehicle capacity for all occupants.
- Use the vehicle risk assessment to inform the fire safety requirements (extinguisher quantity etc.).

Light Vehicles

- This applies to small vehicles such as LIV's for which OEM systems and vehicle structure is largely unmodified.
- Battery isolation and engine shutdown without needing to lift the vehicle bonnet e.g. manual isolation or e-stop.
- One 1.5 kg extinguisher in reach of the driver.
- A second 2.5kg extinguisher accessible via the rear tailgate.

Ali-carts

- Ali-carts are motorised trolleys, not HRVs, but are included for comparison. Fire load is very low.
- One small extinguisher (1kg or similar).
- One fire blanket

6.33 Exhaust systems

To qualify as Tunnel Suitable an existing HRV must comply with items marked # below.

1. # The exhaust system must include a muffler.
2. The outlet must be positioned to direct fumes away from the operator and any bystanders.
3. The exhaust system must be so designed and shielded where necessary to avoid contact with fluid splashes and burn injury.
4. Routing closer to the fuel tank than the OEM design may need splash and heat shields. Shields should not be horizontal or otherwise allow the accumulation of oil, dirt and debris.
5. HRVs to be used in tunnels and other confined spaces:
 - a) must be diesel powered
 - b) # must not emit clearly visible smoke as required to pass a CoF inspection
 - c) # must meet any other conditions required by individual site safety plans.
 - d) if new, must be fitted with:
 - i) an OEM catalytic converter, or
 - ii) an equivalent KiwiRail approved catalytic converter, or
 - iii) a KiwiRail approved scrubber system.
6. # The vehicle's emission system, including both hardware and software, must operate as originally intended, unless KiwiRail has authorised a modification.
7. # A selective catalytic reduction (SRC) exhaust system fitted to an HRV must operate correctly, including correct dosing with fluid, for example, AdBlue.

8. # Risks associated with an engine that follows momentary regeneration cycles must be assessed and mitigated. These are typically heat generation, posing a fire risk, and particle emissions, presenting a hazard in tunnels and other confined spaces.
9. # All engines, and especially older engines, need to be managed as if they are producing toxic and asphyxiant outputs.

Information – Exhaust emissions in tunnels

Tunnel site safety plans will impose requirements for positive ventilation to remove or dilute harmful exhaust emissions and improve safety should a fire occur. All vehicles including Tunnel Suitable vehicles may be required to cease operation should the ventilation become inadequate.

6.34 Footsteps and handgrabs

Adequate access to all work areas of the vehicle must be provided. Where this requires the use of ladders, footsteps or handgrabs, these must be positioned in an ergonomic arrangement (the most efficient way for the human body to use them), and be within the profile limits in 6.1 [Profile](#).

Note also the marking requirements in 6.38 [Marking and documentation](#).

6.35 Cab

Adequate heating and ventilation must be provided in the cab to ensure that the operator is comfortable and alert.

Visibility from the cab for either working or travelling must be unobstructed.

6.36 Operating position

The operator's position must be laid out in a logical and ergonomic arrangement.

Seating must provide impact and vibration absorption.

6.37 Electrical systems

Electrical systems will normally be 12 or 24 Volts DC. Vehicles incorporating equipment operating above 50 volts AC or 120 Volts DC are subject to the inspection and Warrant of Electrical Fitness requirements applicable to caravans with their own internal power supply.

Access to battery terminals for jump starting is required. Remote terminals may be needed after E-Stops are added.

6.38 Marking and documentation

The following information must be clearly displayed in NZ English on the vehicle:

1. all NZTA requirements (Registration plates, Licence label, Certificate of Fitness etc)
2. on any vehicles with ladders, handgrabs or any other facility allowing access to a standing position higher than 1.8 metres above rail level, clearly legible labels or lettering with the wording "Danger Live Wires Above" with the electricity hazard symbol. Suitable labels are available from Admark Visual Imaging Ltd.
3. any warnings, cautions or restrictions for safe operation
4. loading instructions, where applicable
5. operating instructions, where applicable
6. safe working loads or capacities where applicable in a prominent position in lettering 150 mm high (or, if this is not possible, as high as available space permits).

6.39 Hi-rail light trailers

The requirements of section 4 [Approvals](#) and section 5 [Periodic inspection process](#) shall apply to hi-rail light trailers.

Brake performance on rail for the combination of towing vehicle and trailer must comply with the requirements for brake performance of HRVs in section 6.22 [Brake performance on rail](#). It may be necessary to fit trailer brakes to achieve this. Tested and approved vehicle and trailer combinations are to be documented in the vehicle manual for the trailer.

The vehicle manual, including the Type Approval Certificate, is to be carried in the towing vehicle at all times.

The requirements of Section 6 [Common design requirements](#) shall apply to Hi-Rail Light Trailers except that:

- 6.15 Warning Lights need not be fitted to Hi-Rail Light Trailers, but the Warning Lights of the towing vehicle must still comply with clause 6.15 when the trailer is attached.
- 6.17 Reversing Beeper is not required.
- 6.18 Horn is not required.
- 6.19 Train Control Radio is not required.
- 6.34 Cab does not apply.

Maximum Gross Laden Weight for the trailer shall be the lesser of:

- 2000 kg (or other weight approved by KiwiRail)
- the maximum towing capacity of the towing vehicle specified by the Certifying Engineer.

Towing connection is to be 50 mm heavy duty ball and coupling to NZS 5232.

6.40 Trolleys used with HRVs

Trolleys used in conjunction with HRVs will generally be certified in their own right to OM94002 Maintenance trolley requirements.

Trolleys that are an inherent part of a hi-rail vehicle and that cannot be uncoupled from it (i.e. separation requires some degree of dismantling) will be certified as part of the hi-rail vehicle and do not require separate certification. Examples include trolleys carrying work heads such as measurement devices. The complete vehicle must pass all Code requirements in all configurations, eg, trolleys both deployed and stowed.

Trolleys carrying ancillary equipment such as power packs or demountable trolleys such as cable drum carriers will generally be treated separately from the parent vehicle and certified to OM94002 Maintenance trolley requirements.

Trolleys used as rail trailers to carry loads on rail only, and which can be uncoupled from the towing hi-rail vehicle are to be separately certified to the OM94002 Maintenance trolley requirements. Examples include trolleys to carry sleepers or other materials and "dollies" used to carry some of the weight of an excavator attachment.

All other configurations will be considered by KiwiRail on a case-by-case basis.

To avoid an electrical path through the drawbar when vehicles are coupled, KiwiRail prefers the double spark gap approach.

CAUTION

Some trolleys and all road capable Hi-Rail trailers do not have the break-in-two stopping protection or brake system found on rail vehicles in a train. Trolleys and hi-rail trailers may therefore be **totally** reliant on the mechanical drawbar and safety chain connections to avoid a trolley or trailer runaway, as is equivalent practice with most on-road trailers. The vehicle manual must state that such mechanical connections are safety critical items of hardware, and that any concerns around their condition must be handled urgently. If inspection or repairs are needed, operation of the equipment must stop until these issues are adequately addressed.

⚙️ Design Note

HRVs are often favoured for track maintenance work because they can clear the line quickly to allow trains to pass. Care must be taken to ensure that the use of trolleys and trailers in conjunction with HRVs does not unduly compromise this flexibility.

⚙️ Design Note

Particular attention must be paid to ensuring that trolleys of any form used with HRVs cannot run away during on tracking and off tracking operations, especially when not all braked wheels are in contact with the rails at once, or if a trolley is uncoupled from its towing hi-rail vehicle, or derails.

6.41 Operator protective structures (OPS)

It is a general expectation that excavators and other vehicles at risk of tipping while hi-railed are fitted with an appropriate operator protective structure. This also applies to other vehicles capable of swivelling and dumping.

Any OPS that has become damaged in any way must be re-certified by a Certifying Engineer according to this Code. Slight deformations or changes in shape may affect the HRV clearance gauge. Note IPENZ Practice Note PN 12 and particularly the requirement to attach an identification plate.

Manufacturers and operators of hi-railed equipment are advised to discuss requirements for OPS with KiwiRail before commencing their project.

7. Specific design requirements

7.1 Cranes and elevating work platforms (EWP)

See also section 6.14 [Stability](#)).

Cranes and elevating work platforms must be designed and certified in accordance with the applicable WorkSafe Approved Code of Practice or Best Practice Guidelines.

KiwiRail requires a Chartered Professional Engineer to certify EWPs and cranes.

1. The full load path of a crane or EWP must be included in its design and certification. This includes the hi-rail equipment if the crane or EWP can work with the vehicle standing on its rail wheels and any chassis elements in the load path. Certification must clearly state that it includes the hi-rail equipment and any chassis members or connections in the load path to the rails.
2. Deleted.
3. If the hi-railed rating differs from the on-road rating then separate ratings must be stipulated.
4. If the crane or EWP is not able to work to its full capacity while hi-railed then it must be prevented from over-reaching its limits.
5. If the parent machine is dual purpose i.e. it does not always operate as a crane or EWP, then design and certification of the hi-rail equipment as a crane or EWP component must take into account the duty cycle of the alternate use. The stability, control, hose burst and all other functional requirements of the ACoP or Best Practice Guidelines must be met.
6. Certification of cranes and EWPs for use when hi-railed must take into account, canted track (70 mm + 26 tolerance = 96 mm), track defects, and windy conditions.
7. The rating plate to be affixed to the hi-rail equipment must clearly state that the machine is rated for operation while hi-railed and on canted track. This rating must also be included in the vehicle manual. The vehicle manual must list all restrictions on operation – including wind.
8. The use of an inclinometer or other devices to prevent use of the EWP on cant beyond its rating is acceptable provided that the device is fail safe.
9. Stability arrangements that rely on rail clamps to secure the vehicle to the track are not preferred and must be specifically approved by KiwiRail. If approved then:
 - a) rail clamps must be interlocked to limit use if not correctly set up
 - b) design and certification must consider the viability of rail clamp operation, e.g, quality of fasteners, use on ballasted floor bridges, with requirements clearly displayed on the machine and in the vehicle manual.
10. Inspections of the crane or EWP to satisfy regulatory requirements must also include the hi-rail equipment and full load path if the crane or EWP can be used while standing on its rail wheels.
11. A copy of the design certificate of new cranes or EWPs must be included in the vehicle manual.
12. A copy of current crane or EWP inspection certificates must be kept with the vehicle manual and must be available for inspection at any time.

Design Note

If the crane or EWP is not able to work to its full capacity while hi-railed then it must be prevented from over-reaching its limits. Reliance on manual switching to prevent a crane or EWP from over-reaching its limits has proved prone to operator error in at least one case. Interlocking with the hi-rail gear is recommended.

7.2 Pantographs

Pantograph uplift force is to be between 9 and 10 kg. A check on uplift force is to be included in the vehicle's maintenance procedures.

A pantograph must NOT be used as a formal earthing device i.e. it must not be part of the process of earthing the overhead line. Pantographs may only be deployed under isolated and earthed overhead. These restrictions are to be stated on the safety page of the vehicle manual and included in the staff induction check list.

In case of inadvertent energisation the pantograph and its earth path to the rail must be capable of taking full fault current. Earth cabling is to have a cross-sectional area of 35 mm².

HRVs equipped with pantographs must be fitted with an approved spark gap bridging the insulated side of the vehicle (or both sides if both sides are insulated) in case the pantograph comes into contact with live overhead while the insulated side of the vehicle is standing on the traction earth rail.

Pantographs must not be able to rise by themselves. Air-operated pantographs must be held in the retracted position either by normal spring pressure or a physical restraint. The airline must be open to atmosphere when the pantograph is retracted (so that valve leakage cannot pressurise the raise mechanism).

Six-monthly checks on pantographs and earthing are required and are to be included in the vehicle's maintenance procedures.

7.3 Self-laying tracks

Vehicles such as excavators and crawler-carriers with self-laying tracks must have approved cleats fitted to the tracks to avoid damage to rail and other track components.

7.4 Excavators

The characteristics of each vehicle type must be carefully understood during the risk assessment stage.

The Certifying Engineer must state the amount of work the machine can do while running on its hi-rail gear taking into account both static and fatigue loadings and considering all vehicle configurations and movements.

The work a machine can be rated to while running on its hi-rail gear will be somewhere between "none" and "unlimited" (i.e. hi-rail equipment designed to withstand the machine working as an excavator to the point of instability). If the hi-rail equipment is fit only for a limited range of machine activities, it is preferred that load and radius limits be related to key activities that may be undertaken on track, e.g.:

- hi-rail gear fit only for travel with machine unladen
- carry and spread buckets of ballast
- carry a specified number of concrete sleepers weighing 220 kg each
- carry a 12.8 m length of rail, weight 640 kg
- clear scrub
- use a thumb to insert or remove a sleeper
- lift a mini tamper weighing 360 kg
- unlimited work to the point of instability (the hi-rail gear can withstand any work that is safe in the operator's judgement for the life of the machine).

If the engineer rates the machine for a particular limited load, it needs to be noted whether that is for in-line travel or 360 degrees of slew.

7.5 Imported HRVs

KiwiRail may waive some or all of the type approval requirements specified in section 4 [Approvals](#)) for HRVs imported from Japan that are fully documented and in good working order. KiwiRail reserves the right to reject outright, or require full type approval for, any imported vehicle that it is not fully satisfied with.

Potential purchasers of imported HRVs should discuss their intentions with KiwiRail before purchasing. In particular, any vehicle that will be classified as Specialist Hi-Rail Plant in terms of section 2 [Definitions](#) must be discussed with KiwiRail before purchase. Requirements will be set for each individual HRV. Purchasers must confirm KiwiRail's acceptance requirements for their particular vehicle in every case.

Before you buy

KiwiRail strongly recommends that you discuss your intentions with them first if you are thinking about buying an imported hi-rail vehicle.
If the vehicle will be classified as 'Specialist Hi-Rail Plant', as defined in Section 2 of this Code, you must discuss your plans with KiwiRail first.

CAUTION!!

Differences between overseas and New Zealand railway systems may mean that imported vehicles do not physically comply with New Zealand requirements for loading gauge clearances, wheel profiles, wheel back-to-back dimensions, etc.
New Zealand track conditions and operating practices differ from those found overseas and equipment used overseas may not necessarily be well suited to these. Operators must satisfy themselves that imported equipment is suitable for both the task and local conditions. Be aware that different regulatory requirements may also apply.

7.5.1 Policy

KiwiRail will generally prefer HRVs to be capable of operating at 50 km/h on rail.

Original evidence of the safe on-rail speed set by the manufacturer must be presented.

The maximum speed on rail will be the lower of speed set by the manufacturer or the speed set by KiwiRail and is not to be exceeded.

The vehicle and hi-rail equipment must be in good working order.

Any attachments, such as cranes or work platforms, and their attachment to the vehicle chassis, must be certified in their own right by the appropriate authority.

Any other ratings for the vehicle or attachments, such as the electrical insulation of work platforms, must be certified to New Zealand requirements by the appropriate authority.

Any modifications to the vehicle's chassis must be certified in their own right by the appropriate authority.

Original manufacturer's plates and certifications of the hi-rail equipment must be in place on the vehicle.

Original operating manuals must be available. This applies to both the hi-rail equipment and any attachments, such as cranes or work platforms. Manuals not in English must be re-written into English easily understandable by New Zealand crew.

All control labels must be in New Zealand English.

Any part of the original manual reflecting overseas practice, such as operator qualifications, must be re-written to reflect New Zealand requirements, eg, "Only certified Level C operators with an appropriate HT licence may operate this vehicle on rail".

Where tyres form any part of the drive chain during operation on rail, a written statement from a New Zealand tyre supplier is required specifying the tyre(s) to be used. The statement must be clear that the tyres are rated for road and rail use and must be included in the vehicle manual.

The vehicle must pass all remaining inspections specified in this Code.



7.6 Crawler carriers

Crawler carriers are dumper vehicles with self-laying tracks. The characteristics of each vehicle type must be carefully understood during the risk assessment stage.

The Certifying Engineer must state the amount of work the machine can do while running on its hi-rail gear taking into account both static and fatigue loadings and considering all vehicle configurations and movements.

Generic risks crawler carriers may share with excavators and pivot-steer HRVs include:

- ability to slew their load and dump to the side with the associated instability hazard, and, exceeding the general clearance gauge
- how crew judge that the load is within limits
- ability to raise their load with the associated risks of exceeding the upper loading gauge and proximity to an overhead wire in electrified areas
- in hi-rail mode, similar to excavators, the self-laying tracks are likely to exceed the lower clearance gauge.

7.7 Pivot-steer vehicles

Pivot-steer HRVs are rubber tyred vehicles with articulating chassis. The characteristics of each vehicle type must be carefully understood during the risk assessment stage.

A risk peculiar to pivot steering vehicles is the risk of the vehicle steering mechanism operating while hi-railing. To prevent activation of the pivot steer system while in a hi-railed configuration, interlocks or physical restraints are to be mandated as part of the vehicle's certification requirements. Operator Instructions must require that once positioned on rail, the steering lock must be installed prior to moving off.

The Certifying Engineer must state the amount of work the machine can do while running on its hi-rail gear taking into account both static and fatigue loadings and considering all vehicle configurations and movements.

Generic risks pivot-steer HRVs may share with excavators and crawler carriers include:

- ability to slew their load and dump to the side with the associated instability hazard, and exceeding the general clearance gauge
- how crew judge that the load is within limits
- ability to raise their load with the associated risks of exceeding the upper loading gauge and proximity to an overhead wire in electrified areas.

7.8 Vehicle Safety Indicator Lights

Some construction machines such as cranes and excavators are fitted with coloured lights to indicate whether or not it is safe to approach the machine. The lights usually display red or green.

The following guidelines are provided for lights used to indicate whether or not it is safe to approach a hi-rail vehicle:

- The device must give an accurate indication while the vehicle is hi-railed as well as when it is off-rail. For example, a device cannot be relied upon if the vehicle can still move on rail with a 'safe to approach' indication displayed.
- Lights displayed by the device must be arranged to minimise confusion with safety critical lights such as railway signals.

8. Appendix A. Test procedures

A1 – Measuring Rail Wheel Geometry

A2 – Measuring Rail Wheel Loads

A3 – Measuring Twist Response

8.1 A1. Measuring rail wheel geometry

The following equipment is required to check the rail wheel geometry of HRVs. Only persons certified as competent by KiwiRail may undertake these inspections. Drawings are included in [Appendix C. Drawings](#).

- Road/Rail set-up (back-to-back) gauge 50103060
- Wheel Wear Gauge 50107007
- Wheel Profile Gauge (E1) 50107551

To measure rail wheel geometry:

1. Inspect Hi-Rail equipment for damage and function.
2. Check rail wheel wear using wear gauge 50107007, as described below.

	<p>Flange sharpness W</p> <p>Apply the gauge at W to the corner of the flange.</p> <p>Excessive sharp flange is indicated if the gauge can rock without sliding.</p> <p>No sharp flange is indicated if the gauge cannot rock.</p>
--	---

	<p>Flange thickness X</p> <p>Apply the slot to the flange.</p> <p>Condemn if the tab touches the tread.</p>
--	--

	<p>Flange height Y</p> <p>Apply the Gauge to the wheel with the Z scale flush with the inside of the wheel, and either the point marked V on the tread, or the curve marked Y on the flange.</p> <p>Excessively high flange is indicated if the curve marked Y touches the top of the flange.</p> <p>No high flange is indicated if the point marked V touches the tread.</p>
--	--

	<p>Wheel rim thickness Z</p> <p>Apply the Gauge with the scale flush against the outside of the wheel and the point marked V touching the tread. Wheel rim thickness Z is read off the scale at the gauging line</p>
--	---

	<p>Guttering</p> <p>Maximum allowable guttering is 5mm.</p>
--	--

	<p>Wheel profile</p> <p>Apply gauge 50107551 to the wheel to compare the machined wheel profile with the gauge profile on new or re-profiled wheels. The flange profile of the gauge must fit over the wheel flange to its full depth.</p>
--	---

Back to back using gauge 50103060

1. Either use a KiwiRail verified test location, or
 - a) Locate a straight portion of track at least three lengths longer than the length of the vehicle being checked
 - b) Place vehicle on track and ensure hi-rail equipment is fully lowered.
 - c) Drive forward at least three vehicle lengths
 - d) Drive backwards at least three vehicle lengths.
2. Ensure that all persons and loads have been removed from the vehicle.
3. Take back-to-back measurements of both wheelsets at the lowest point, using gauge 50103060. Record the measurements on check sheet ([Appendix D. Checksheets](#)).

8.2 A2. Measuring rail wheel loads

Wheel loads may be measured using load cells that have a current calibration certificate or the KiwiRail test kit.

The test kit uses the following equipment to check the rail wheel loads of HRVs. Drawings are included in [Appendix C](#).

- Indicator Bar 50106168.
- Test Kit 50102472 Comprising:
 - 2 No. rail beams
 - 1 No. saddle
 - 1 No. hydraulic cylinder (Enerpac RC50 or equivalent) and packers, or
 - 1 No. hydraulic cylinder (Enerpac RC55 or equivalent)
 - 1 No. hydraulic hand pump
 - 1 No. pressure gauge - 0 to 25,000 kPa
 - 1 No. 35 mm test gauge (other sizes may be required).

Note: The equipment included within the test kit may **only** be used for the testing of Hi-Rail equipment. It is not to be used for other purposes.

1. Either use a KiwiRail verified test location, or
 - a) Locate a straight portion of track at least three lengths longer than the length of the vehicle being checked
 - b) Place vehicle on track and ensure hi-rail equipment is fully lowered.
 - c) Drive forward at least three vehicle lengths
 - d) Drive backwards at least three vehicle lengths.
2. Ensure that all persons and loads have been removed from the vehicle.
3. Install rail beams either side of **front** rail wheels. (Ensure insulation is placed on the same rail under both beams if working in a track circuited area).
4. Install saddle between beams (where necessary, jacking direct from sleepers is acceptable).
5. Ensure brake shoes (where fitted) are released on the rail wheel being tested.
6. Couple hydraulic cylinder and hand pump.
7. Install appropriate pressure gauge. Where the machine weight is not known, use a high pressure gauge to determine the pressure range then use the lowest possible pressure gauge to obtain accurate readings
8. Position cylinder under bottom corner of suspension arm or axle as near as possible to the rail wheel.
9. Fit indicator bar to wheel.



10. Slowly raise hydraulic cylinder until rail wheel rotates and indicator bar drops - read gauge and record pressure on the check sheet. (Note: Do not raise more than once - if you are unsure of the reading, recommence at item 3).
11. Calculate wheel load in kg, using the appropriate conversion chart in [Appendix B](#) (Figures 5, 6, 7 and 8) for the ram and pressure gauge used, and record on the check sheet.
12. Repeat process from Item 11 for the opposite rail wheel.
13. Calculate the axle load by adding the left and right wheel weights. Check that this does not exceed 16,000 kg.
14. Measure the wheel running diameter and record on the check sheet.
15. Calculate the maximum allowable wheel load. (Maximum allowable wheel load in kilograms (kg) = $N \times$ wheel running diameter in millimetres (mm) where N is the factor in section 6.8 Maximum axle load. Check that this is at least as much as the recorded axle load.
16. Calculate the side-to-side weight difference from the individual wheel loads. Check that this does not exceed 20% of the lighter wheel.
17. Hi-Rail Plant that exceeds 20% side-to-side weight difference must be restricted to a maximum on track speed of 25 km/h. This is to be noted in the Special Conditions of the Entry Approval checksheet. No vehicles are to exceed 30% side-to-side weight difference.
18. Install rail beams either side of **rear** rail wheels. (Ensure insulation is placed on the same rail under both beams if working in a track circuited area).
19. Install saddle between beams.
20. Where necessary, jacking direct from sleepers is acceptable.
21. Measure rear wheel weights using the process described in items 11 to 19 above.

8.3 A3. Measuring twist response

1. Select the rail wheel with the lowest load.
2. On the same side of the vehicle, install a twist test packer between the other rail wheel and the rail (see Twist Test Packing Chart in [Appendix B](#) below for correct gauge size).

Indicator arm must not drop when fitted to any other rail wheel.

Note: HRV that fails the above twist test, but is judged acceptable for safe operation, must be restricted to a maximum on-track speed of 25 km/h. This is to be noted in the special conditions of the Entry Approval Checksheet.

9. Appendix B. Charts

Figure 1	Wheel diameter – load chart
Figure 2	End overhang calculator for use with standard static gauge
Figure 3	Out of balance calculator. Up to 2000kg wheel load
Figure 4	Out of balance calculator. 2000 kg to 8000 kg wheel load
Figure 5	Twist test packing chart
Figure 6	Pressure to weight conversion chart. High load for use with RC50 and RC55 cylinders
Figure 7	Pressure to weight conversion chart. High load for use with RC102 and RC106 cylinders
Figure 8	Pressure to weight conversion chart. Low load for use with RC50 and RC55 cylinders.
Figure 9	Pressure to weight conversion chart. Low load for use with RC102 and RC106 cylinders.

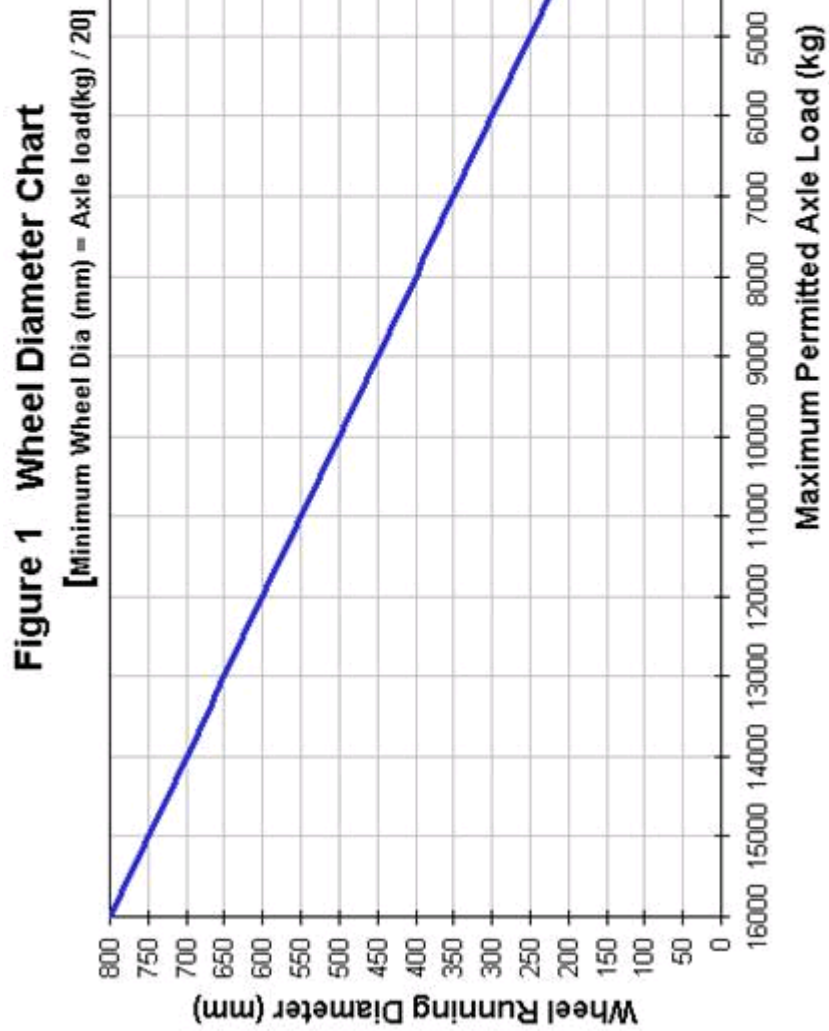
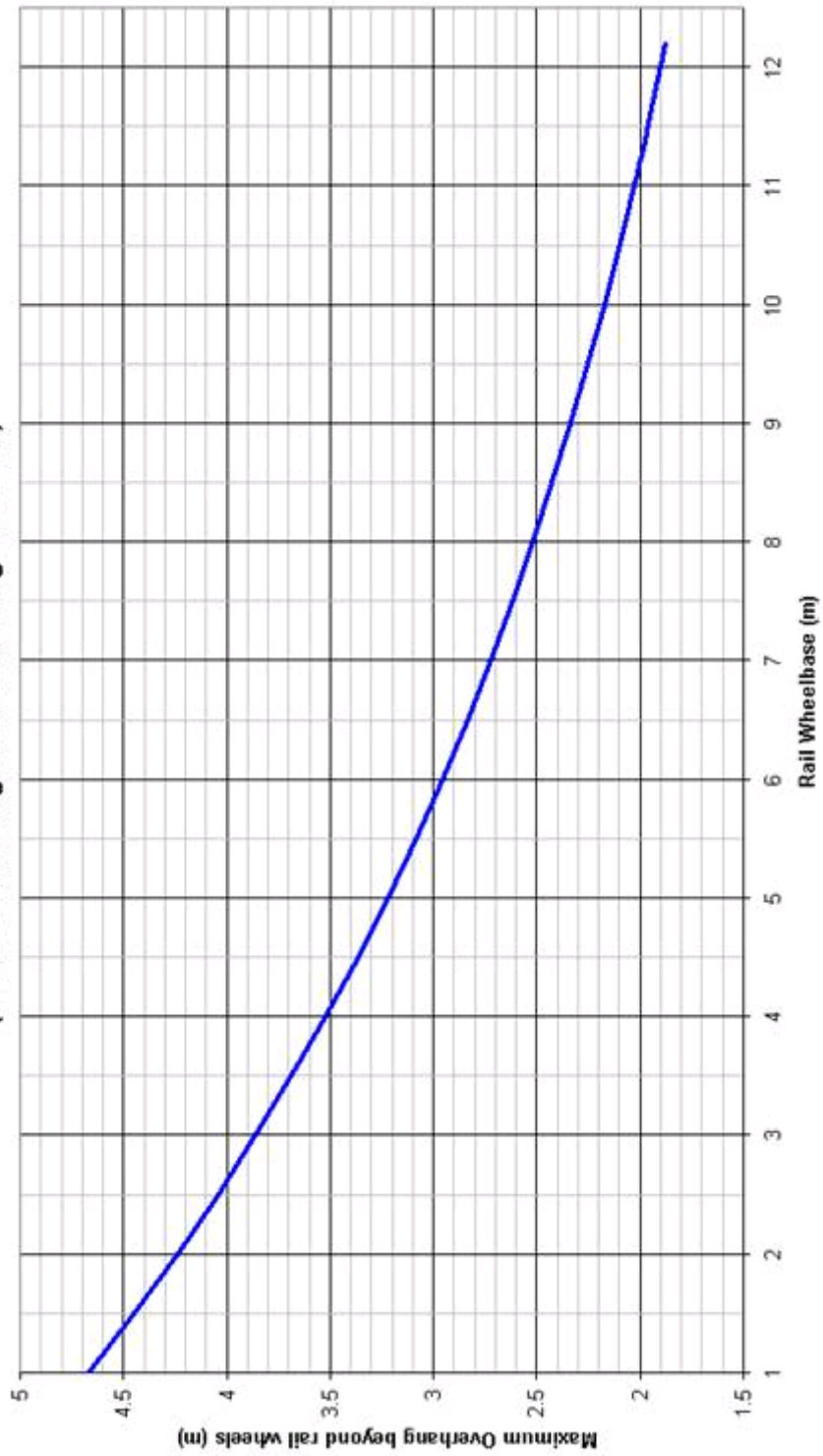
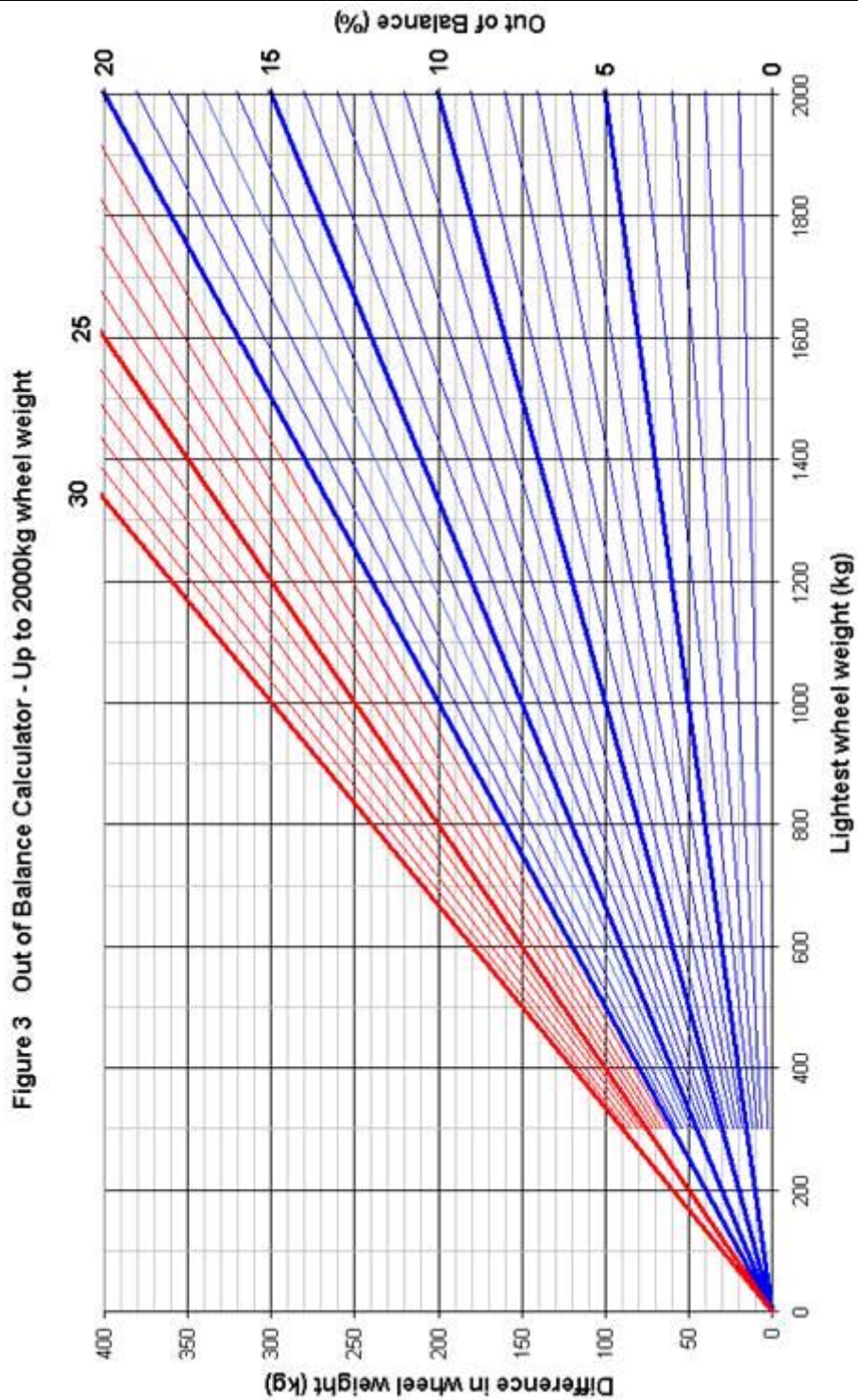

Figure 2 Maximum Overhang Beyond Rail Wheels
(For use with Rolling Stock Static Gauge 13090429)





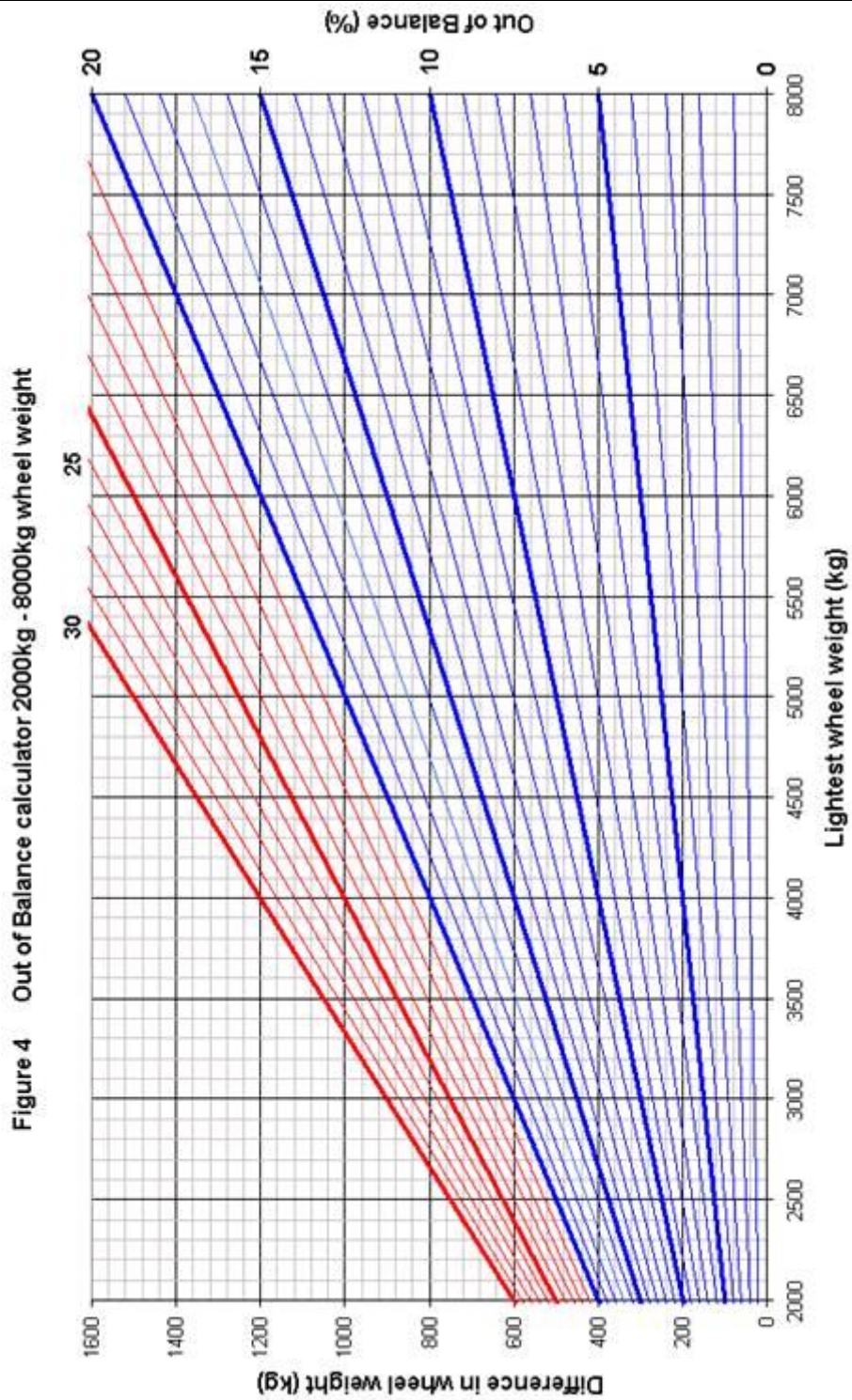

Figure 5 Twist Test Packing Chart

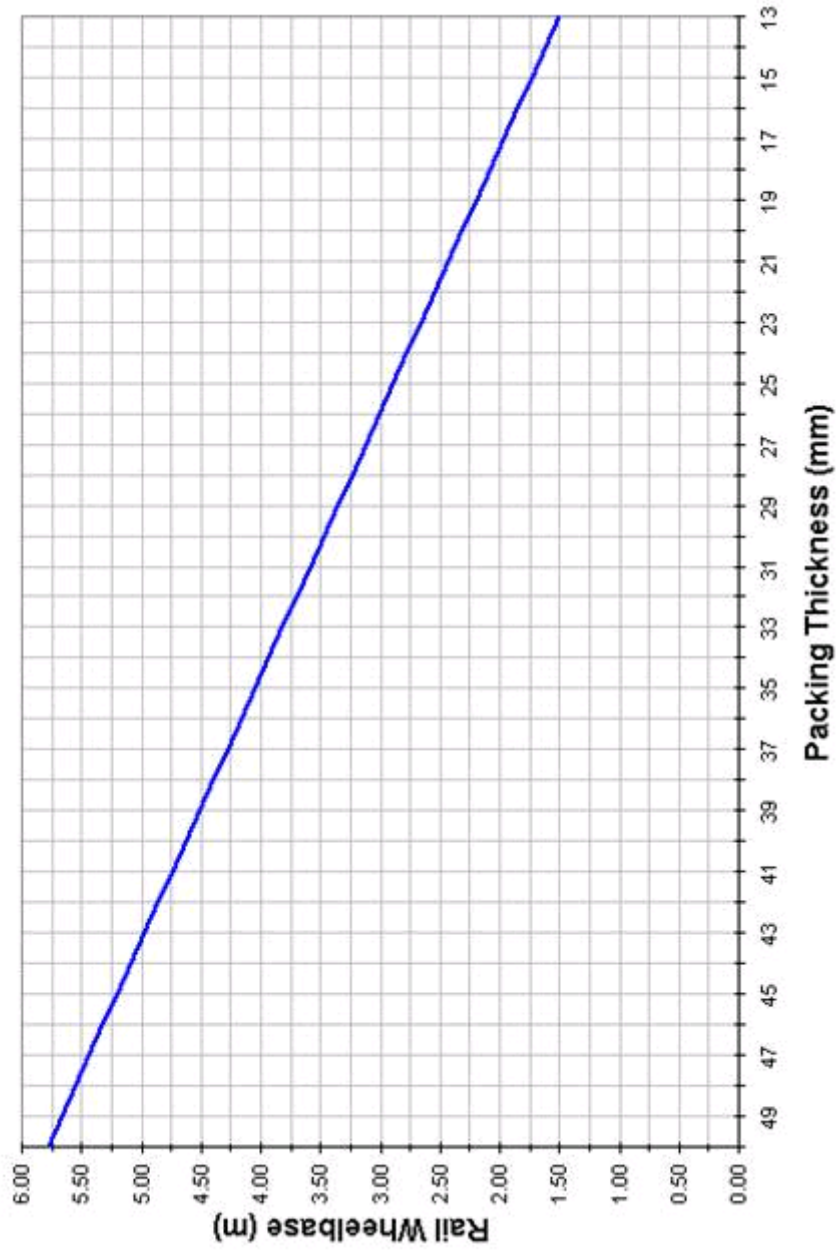

Figure 6 Approximate Weight Conversion Chart (kPa to kg)
High Load for use with Enerpac RC50 and RC55 Rams

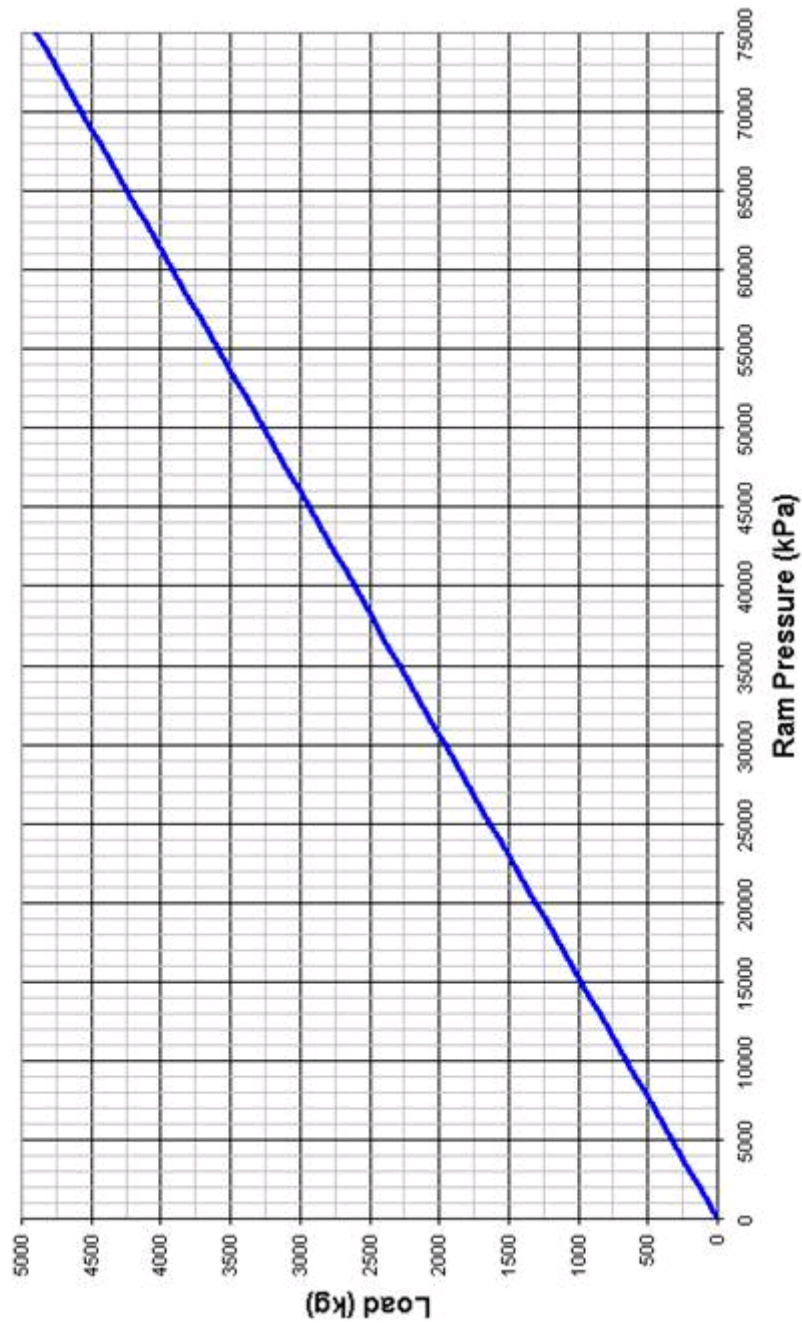

Figure 7 Approximate Weight Conversion Chart (kPa - kg)
High Load for use with Enerpac RC102 and RC106 Rams

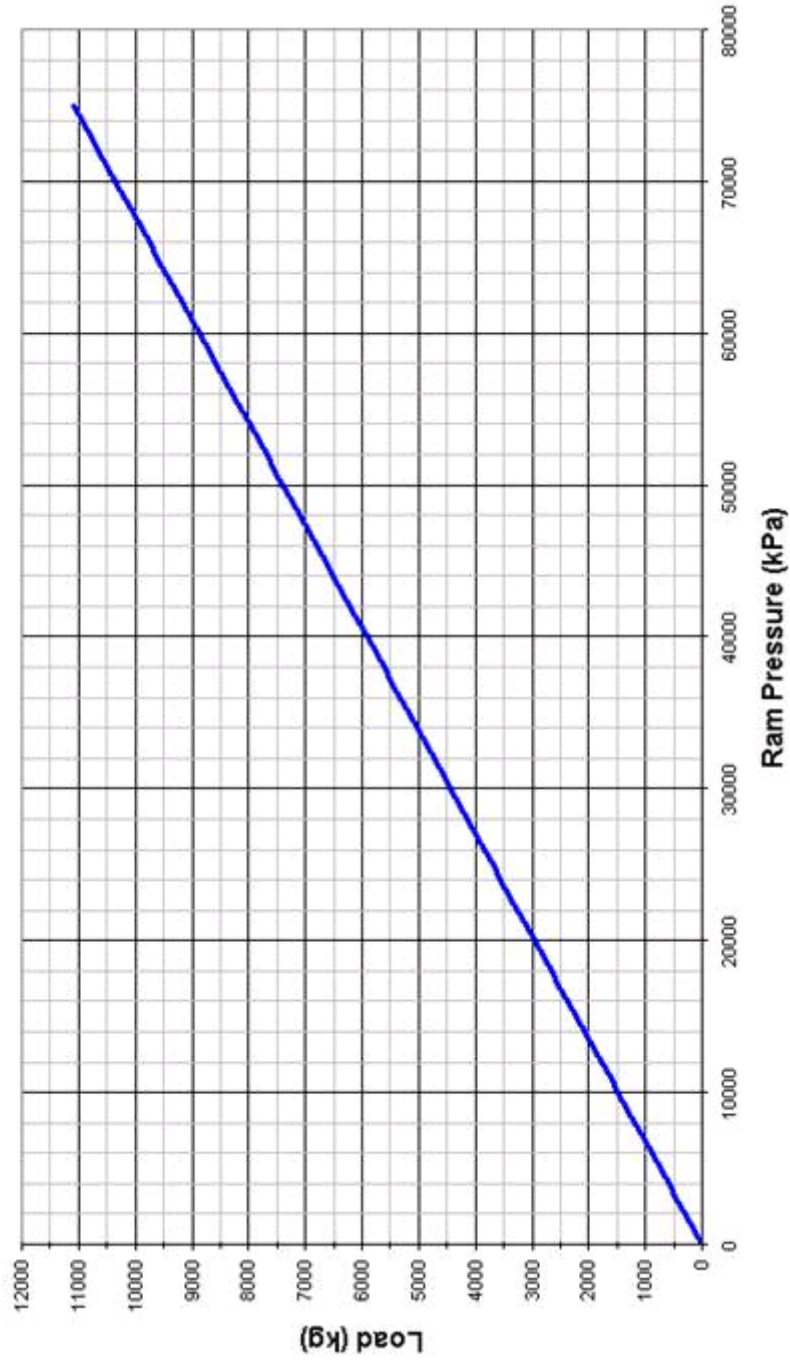

Figure 8 Approximate Weight Conversion Chart (kPa to kg)
Low Load for use with Enerpac RC50 and RC55 Rams

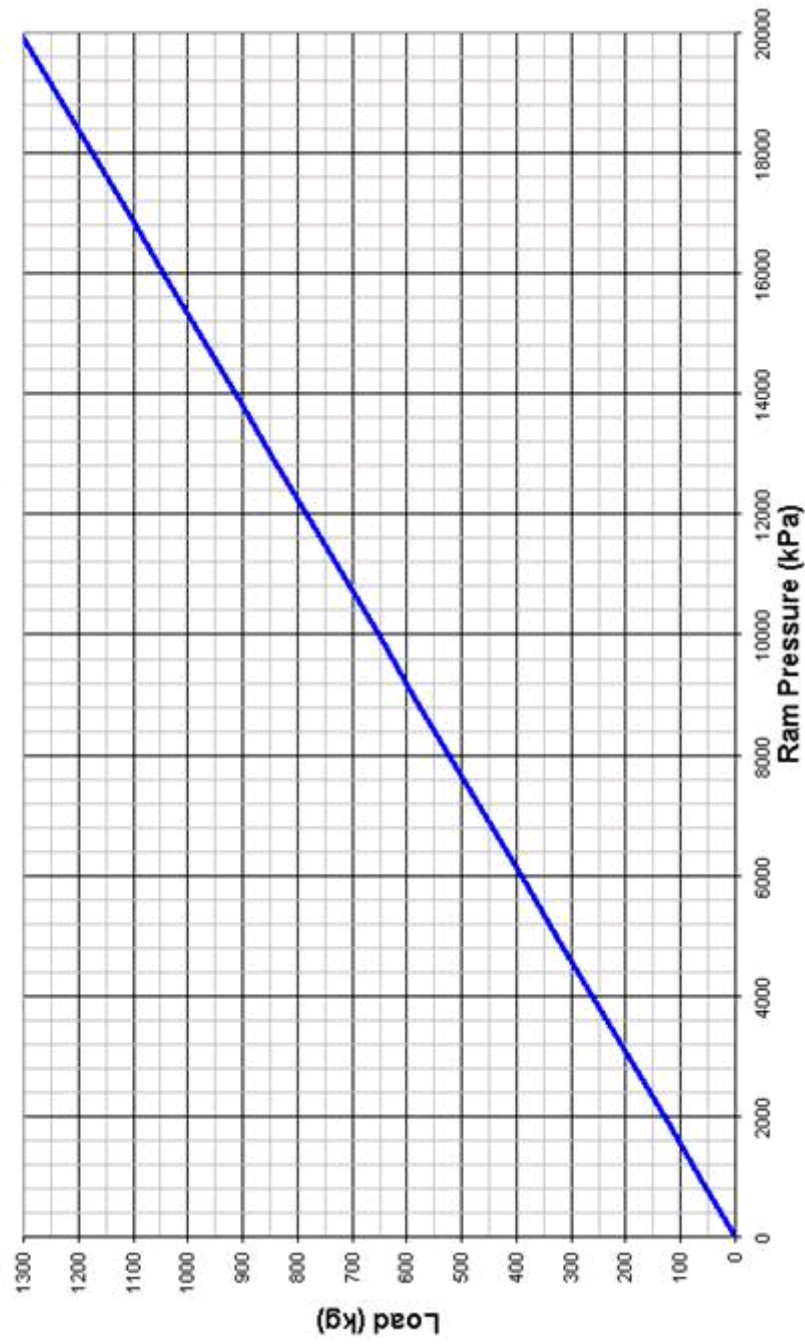
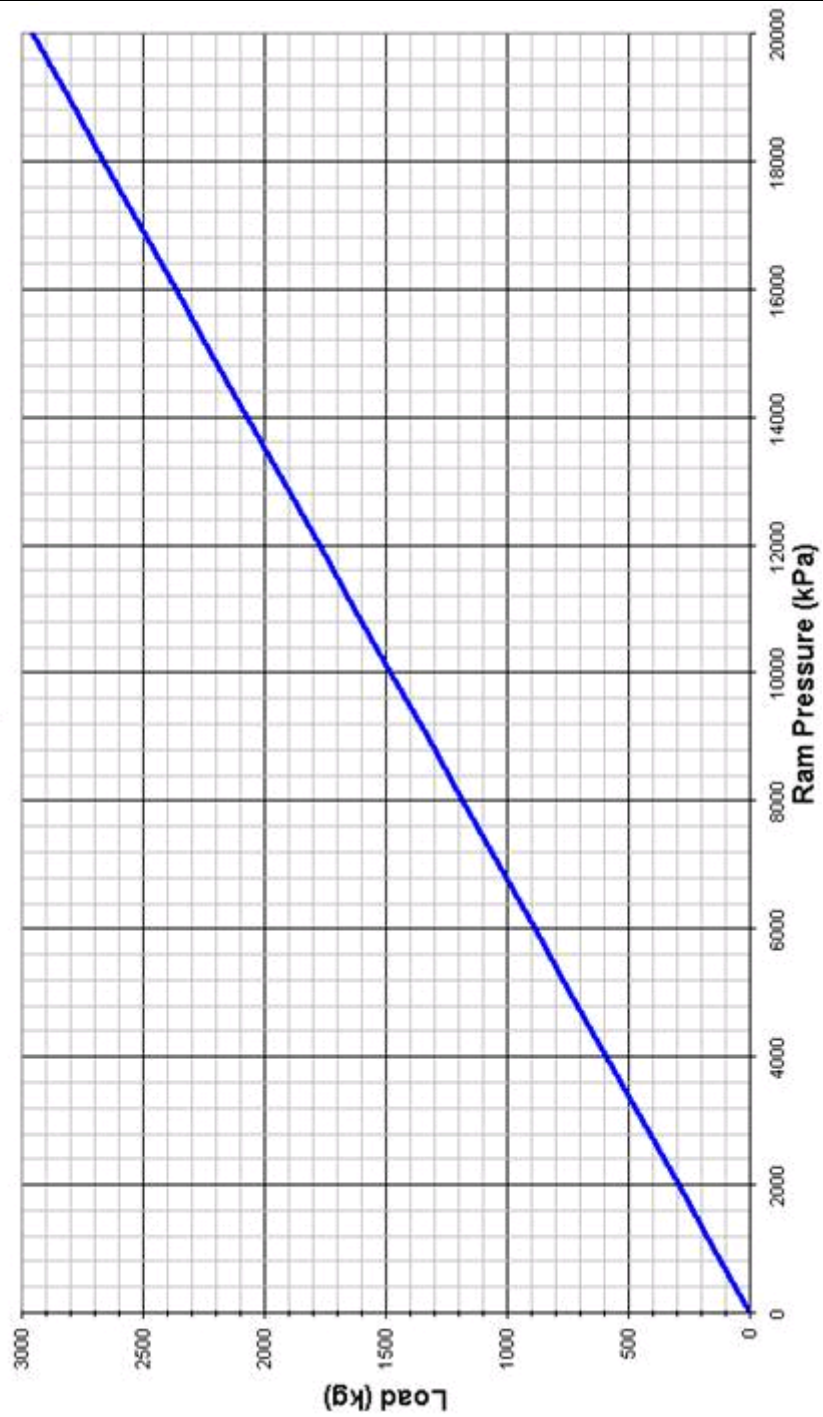
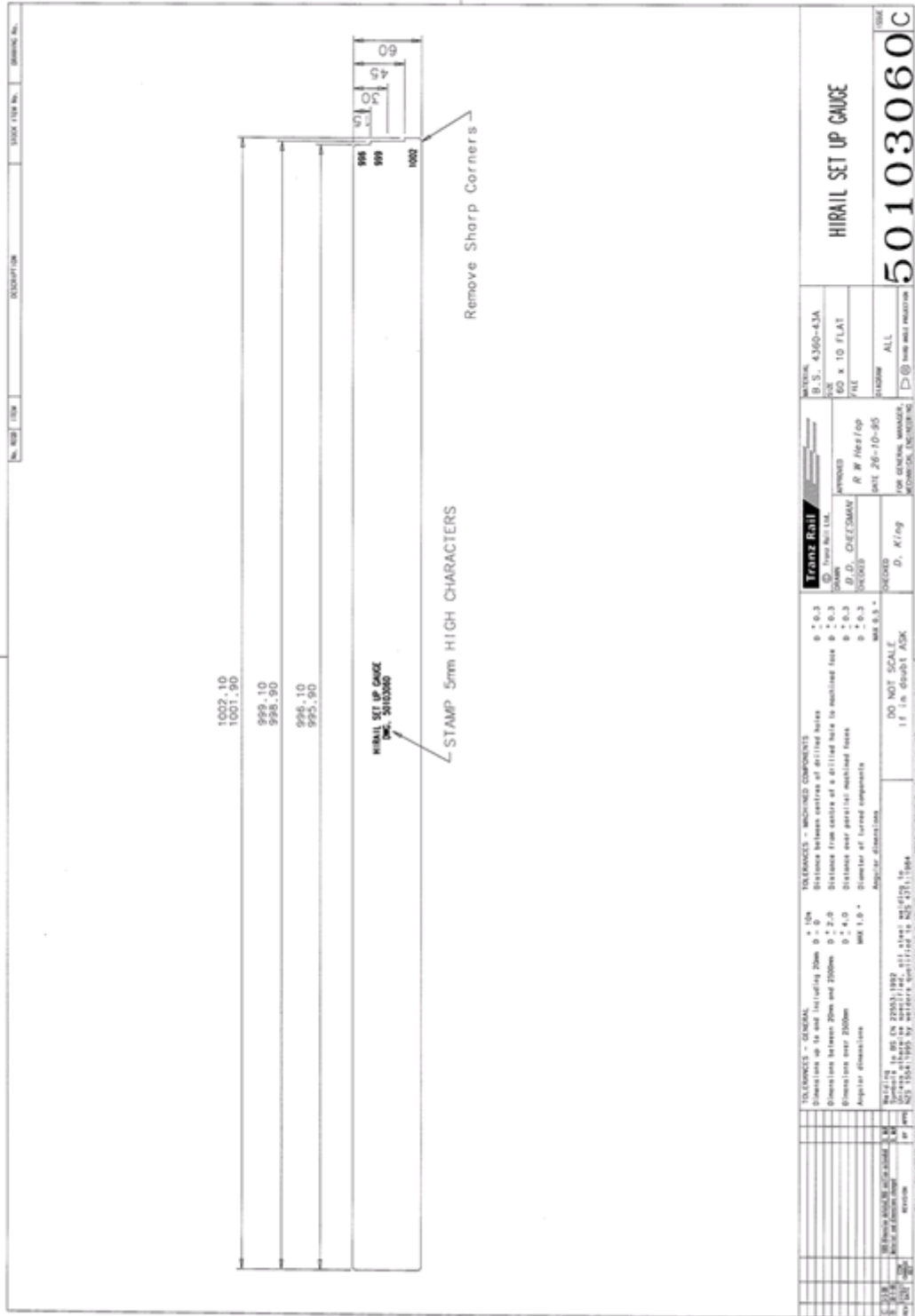

Figure 9 Approximate Weight Conversion Chart (kPa - kg)
Low Load for use with Enerpac RC102 and RC106 Rams



10. Appendix C. Drawings

50102472	Flexiride suspension test kit
50103060	Back to back gauge (Hi-Rail set up gauge)
50106168	Road/Rail vehicles test kit indicator bar
50107007	Hi-Rail wheel gauge: gauge for checking wheels
50107551	Wheelset manual: E1 profile gauge



11. Appendix D. Checksheets

Checksheets are published separately from this manual. Refer to the following documents:

- Loco 710 HRV Entry Approval Checksheet
- Loco 711 Application for 160A Hi-Rail Inspection
- Loco 160A HRV Inspection Checksheet
- Loco 712 Vehicle Inspection Checksheet

12. Appendix E Type approval certification

12.1 Overview

Application to KiwiRail for type approval by a Certifying Engineer must include data and statements of compliance against the following detailed schedule of requirements.

Some requirements may not be relevant to the application at hand in which case an "NA" statement can be made. The format of an application is not fixed but a statement against each requirement is mandatory. This schedule may not be complete.

The Certifying Engineer is responsible for defining equipment capabilities and operational limitations (on and off rail) including all worst case operating scenarios.

Certification is to generally cover: who is certifying, what is being certified, how the certificate is given (methodology), and any limitations. The certification documentation consists of the following four sections:

1. Certification statement
2. Vehicle description
3. Compliance statements (including exceptions and certifications from others)
4. Limitations and conditions.

12.2 Certification and certifier details

1. Name.
2. CPEng Registration number and any other relevant transport qualifications.
3. Vehicle owner.
4. Vehicle modifier.
5. Certification plate serial number.
6. Statement as to whether Type Approval Certification applies to following production or if Certifier must sign-off individual vehicles. If type approval applies to following production, state quality assurance and third party certification required.

12.3 Vehicle description

1. KiwiRail identity number allocated.
2. NZTA Registration for road-going vehicles.
3. Diagrams or photos sufficient to show vehicle arrangement.
4. Base vehicle make, model and serial number.
5. Tare mass and axle loads on and off rail. Tare is to be actual measured figure to avoid error or omission in ratings and capabilities.
6. Gross vehicle mass (GVM), axle loads on and off rail and payload (as relevant).
7. Maximum towing capacity on and off rail.
8. Added Hi-Rail equipment make, model and serial number.
9. Added lifting equipment or platforms make, model and serial number.
10. OPS.
11. Overall dimensions on and off rail.
12. Maximum speed/restrictions (load, reach, slew, cant, wind speed).



13. Payload on and off rail.
14. Tyre type, size and pressure.
15. Crane and/or EWP SWL lift/reach capacity for boom and stabiliser legs.
16. Location(s) of earth paths.
17. Trailer rating on and off rail.
18. Trolley rating on rail.
19. Base machine kilometres or operating hours.

12.4 Compliance statements

The Certifier is to include an explicit statement of compliance against the following clauses:

1. KiwiRail OM 94001 and OM94002 particularly noting any exceptions.
2. ACoP and or crane or EWP.HRV certification to cover dual road/rail use as relevant for such attachments.
3. PECPR.
4. HV approval certificate, HV Specialist Certifier name and Registration number.
5. Standards for weld processes, weld quality and welder qualifications.
6. Standards for design of weldments for static and fatigue duty.
7. Standards for design of shafting/axle design.
8. Other codes and standards used to derive design.

12.5 Limitations and conditions

1. Restrictions on the use of the machine required to ensure efficient and safe operation.
2. Any statements limiting or voiding certification and liability. There must be a prominent statement that certification is invalidated if the equipment is modified, damaged or requires major repair.
3. Expiry of certification.
4. Minimum inspections, servicing and maintenance – from daily tasks to scheduled requirements. To include detailed inspections such as axle NDT etc. at specified intervals.
5. Physical or diagnostic checks required to ensure efficient and safe operation.
6. Any specific training requirements.

12.6 Vehicle Documentation

7. Confirmation that key material related to the safe maintenance and operation of the vehicle has been incorporated in the vehicle manual (see Appendix G) with particular attention to the following key areas:
 - a) An adequate maintenance regime has been specified.
 - b) There are adequate operating instructions.
 - c) Key risks, hazards and emergency instructions are listed on the safety page.
 - d) There is an adequate training and competency syllabus.
 - e) The vehicle risk assessment is adequate.
 - f) Where AFFSS is fitted an installation report and risk assessment has been provided that is specific to the vehicle type and that AFFSS maintenance requirements have been included in the vehicle manual.

13. Appendix F. Risk management

13.1 Overview

The fundamental objective of the risk management process is to influence safety by identifying potential hazards and then ensuring hardware, manuals, training and operations achieve the necessary mitigations. This is to be decided by those responsible for the machine design, maintenance and operation and be acceptable to KiwiRail.

13.2 Content

The output of the final risk assessment must be presented in the vehicle manual in a form readily understandable to the crew.

1. Conduct risk assessment to NRSS/4.
2. Mitigate each risk by design, maintenance and operations to the standard that Certifier, Owner and Operator sign-off on final mitigations and residual hazards.
3. Start at design stage to ensure design mitigations are incorporated and update as necessary as the machine takes shape and is presented for approval.
4. Incorporate operational risk mitigations into vehicle manual, instructions and training.
5. Owner/Operator is responsible for maintenance mitigations (or resourcing them).
6. Operator is responsible for operating mitigations – ongoing training, competency and work instructions.
7. Include critical aspects of the final risk assessment into the safety page.
8. Hazards are to include foreseeable as well as historical scenarios.
9. Cover novel features and points of difference to other machines.
10. Conduct a preliminary hazard assessment, which might typically include:
 - a) Electrocution.
 - b) Runaway (particularly ‘free-wheeling’ risks during on tracking and off tracking and the impact of grades on the braking capacity of an HRV).
 - c) Derailment.
 - d) Impacting with object/person.
 - e) Overturning.
 - f) Stopping (steep grades, poor adhesion, other HRV nose-to-tail collisions).
 - g) Fire safety, including inside a tunnel.
 - h) Other hazards depending on vehicle type.
11. Operator must always have up-to-date risk assessment reviewed and counter signed by operating management and sample crew whether vehicle is owned, leased or hired.
12. Review the risk assessment after any vehicle modifications.

Information Note

Sample registers to help you get started may be obtained from KiwiRail.



14. Appendix G. Manuals

14.1 Overview

Manuals must communicate all the necessary operating, maintenance, training and safety requirements to allow safe and efficient use. They must be based on an understanding of the equipment as defined by the Certifying Engineer ([Appendix E](#)) and agreed risk management (Appendix F) to the satisfaction of KiwiRail.

1. The owner is responsible for preparing (or resourcing of) vehicle manuals.
2. Operating and maintenance instructions must address all hazard mitigations allocated to them.
3. Vehicle manual must be in the cab or control station at all times. HRV owners must retain an office master copy in some form that can be reproduced as required for audit or replacement copies.
4. Manuals must cross reference other sources, especially other volumes if all information is not in one volume.
5. Language must be concise and in plain NZ English appropriate to the reader.

14.2 Content

Vehicle manual to include, in order:

1. Cover page to identify vehicle make, model, ID of vehicle (VIN and registration number) and KiwiRail identity number this copy belongs to and is to include a statement that the vehicle must not be used on rail after modification until it has been recertified and that major repairs may also require certification.
2. Safety page (to be boldly identified and to follow the cover page) and include:
 - a) critical on tracking and off tracking procedures e.g. runaway avoidance
 - b) slew limits, tip limits, lift limits, load limits
 - c) any speed restrictions
 - d) critical aspects from the risk assessment.
 - e) reference to critical emergency procedures e.g. grounding to arrest runaway.
 - f) A statement that any major faults or repairs are to be recorded in the log book provided for the purpose.
3. Contents page.
4. Quick reference of key operating instructions (to be follow the contents page) and to include:
 - a) image(s) of vehicle for quick identification
 - b) maximum speed and any other restrictions (load, reach, slew, cant, wind speed)
 - c) GVM, tare mass and axle loads on and off rail.
 - d) payload on and off rail
 - e) tyre types and pressure
 - f) EWP or crane lift and reach capacity for lifting boom and stabiliser legs
 - g) location(s) of earth paths
 - h) trailer rating on and off rail
 - i) trolley rating on rail.
5. Technical information:
 - a) overall dimensions on and off rail



-
- b) diagrams or photos covering both ends, both elevations and plan view to show configuration of vehicle. These images are essentially to allow a check that no significant changes have been made to the vehicle
 - c) general description of machine, attachments and how all key features work, especially:
 - i) service brake(s) – road and rail
 - ii) parkbrake(s) – road and rail
 - iii) on and off tracking attachments
 - iv) traction drive on rail (direct or friction) etc
 - v) link understanding of equipment to runaway/free-wheeling risks during on tracking and off tracking and the impact of grades on the braking capacity of an HRV.
 - d) Reference information (Appendices).
 - vi) Risk management plan (see Appendix F).
 - vii) Copy of HRV Type Approval Certification and HV Certification (Appendix E).
 - viii) Copy of crane or EWP design certificate.
 - ix) Copy of crane or EWP inspection certificate kept with vehicle manual.
 - x) Training and competency assessment material (see Appendix H).
 - xi) Daily inspection by operator. (Note compulsory items for Tunnel suitable vehicles.)
 - xii) Servicing schedule.
 - xiii) Fault and repair booking process and maintenance sign-off.
 - xiv) Safety and emergency equipment.
 - xv) Emergency recovery procedure and emergency off tracking (special) procedures – steep grade, chocks, extra crewing etc..
 - e) Maintenance Manual to contain all scheduled inspections and programmed work. For example:
 - i) Integrity checks on safety critical items including checking for unintended consequences of repairs, maintenance and damage. To include operation of all interlocks (list all instructions) and validation of correct machine operation and prevention of incorrect machine operation as relevant.
 - ii) Specific certification inspections such as NDT etc.
 - iii) Include at rear at least 10 blank pages to allow faults and repairs to be booked by crew and signed-off by maintenance personnel. Pages to be lined and columns for date, location and description. Or provide a separate repair booking system (see 3.13 [Fault and repair booking](#)).
 - f) An illustrated checklist showing all safety and operational signage and labels and their location. All non-standard automotive controls to be labelled. These images are to check signs etc. are in place as they should be.
 - g) Checklists are to be the last appendices in the Vehicle Manual for ease of reference by inspectors and auditors.

Note that KiwiRail will formally review all information as one coherent package at the type approval acceptance stage, but is happy to provide guidance as requested at earlier stages.

15. Appendix H. Training and competency syllabus

15.1 Overview

The fundamental objective is to ensure operating crew understand the equipment and are adequately competent and experienced. The owner and/or operator are responsible for ensuring that crew are adequately trained and



adequately assessed for competency. When relevant, this must include a process to assess competency and experience to be a sole operator or person in charge. A training check-list is to be provided in a form that can be signed-off by those giving and receiving training and retained as a record of training.

15.2 Content

KiwiRail anticipates the preparation of all training and competency material will represent a significant volume of work reflecting the importance of the subject to operational safety.

Training requirements are to include how to operate safely, including tunnel fire safety, operating restrictions, key maintenance tasks, control layout, recovery in the event of breakdown, and best-practice operation of the machine. The check-list must include the following:

1. Operator qualifications necessary to operate on the network (sighted?).
2. Operator's qualifications to operate the machine eg, driver licence, TPA or TPBM. Note class of trainee's drivers licence including classes (circle as appropriate: 1 2 3 4 5 6) (sighted?).
3. Personal protective equipment requirements.
4. Awareness of drug and alcohol -free requirements including random audits in line with KiwiRail policy.
5. 155B and WoF or CoF currency.
6. Maintenance up to date.
7. Familiarity with the content and layout of the operator's manual. Know where to find the key information below.
 - a) All safety and quick reference information.
 - b) Identification of major hazards identification including an adequate awareness of the risk assessment information and biggest hazards for this equipment. Include the most significant such as fire safety in tunnels, runaways, derailments, overturning, loading gauge, electrocution etc...Link understanding of equipment to runaway and free-wheeling risks during on tracking and off tracking and the impact of grades on the braking capacity of an HRV.
 - c) Inspection sheets.
 - d) Fault and repair booking process to be covered.
 - e) Location and contents of safety equipment- detonators, flags, first aid, MSD folder.
 - f) Description of correct tyre types and pressures.
 - g) Maximum speed on track, level crossings, speed restrictions, turn-outs.
8. Driver responsibilities including operating restrictions such as in electrified areas and tunnels.
9. Daily operator inspection and pre-start procedures.
10. Weekly operator inspection (where required).
11. On-tracking procedure.
12. Off-tracking procedure.
13. Emergency off-tracking procedure.
14. Procedures to be followed when leaving the cab.
15. Procedures to be followed when leaving the vehicle unattended.
16. Operation on rail including park and service brake configuration and operation.
17. Maximum permitted height of vehicle and load.
18. Driving technique in all conditions eg, wet rail, ice, slippery rail.

19. Where a crane or EWP is fitted - rules for safe operation and the certification required before a person can operate it. Safe stowage and emergency lowering procedures.
20. Safe ride positions e.g. only the vehicle cab and any other designated position such as an EWP bucket.
21. Position, operation and reset of e-stops, if fitted.
22. Location of fire extinguishers.
23. Any other operating or safety requirements, especially any unique to the vehicle.
24. Assessor's judgement of whether or not the candidate demonstrates the appropriate maturity and attitude for the task.

To be deemed competent to operate the machine alone the candidate must successfully demonstrate competence in each of the theoretical and practical tasks above.

As well as listing the points of training and assessment, the training form must include:

25. The printed name of the person giving training.
26. Sign-off by the person giving training certifying that the recipient has demonstrated competence in each of the theoretical and practical tasks listed and that a copy of the form has been retained for the trainer's records.
27. The printed name of the person receiving training and being assessed.
28. Sign-off by the person receiving training certifying that they have received the instruction set out before taking charge of the vehicle and that a copy of the form has been provided for his/her records.
29. Location and date of training.
30. Trainer and trainee to retain copies of the training material and form.

16. Appendix I. KiwiRail-supplied items

Refer to KiwiRail for items such as detonators and standard signage.